

# SK-30 STUMP KUTTER OPERATION & PARTS

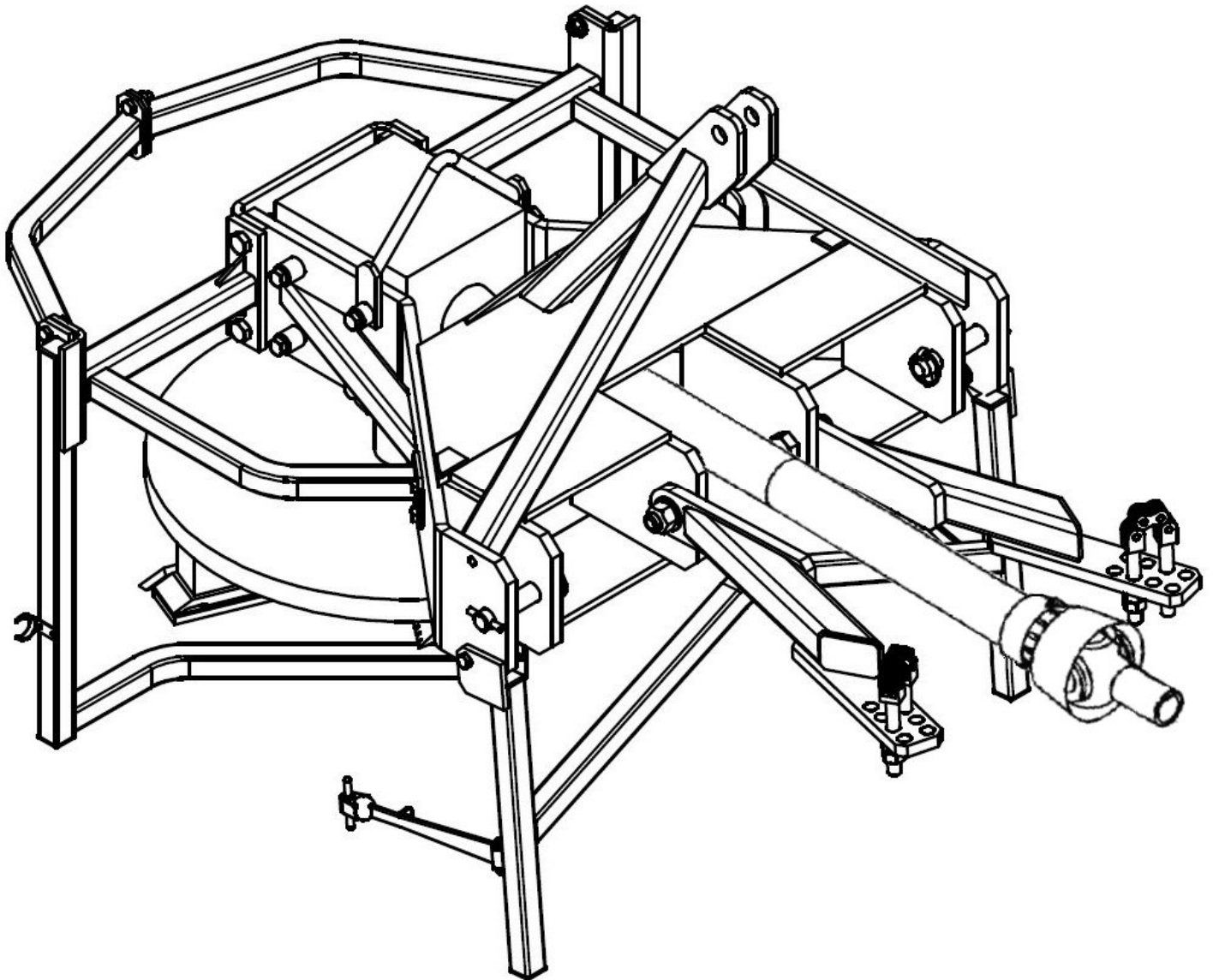



# TO THE PURCHASER

This manual contains valuable information about your new King Kutter Stump Kutter. It has been carefully prepared to give you helpful suggestions for operating, adjusting, servicing and ordering repair parts.

Keep this manual in a convenient place for quick and easy reference. Study it carefully. You have purchased a dependable and sturdy stump kutter, but only by proper care and operation can you expect to receive the service and long life designed and built into the product.

Sometime in the future your stump kutter may need new parts to replace those that are worn. If so, go to your dealer and provide him with the model and part number.

## Customer Information

Name \_\_\_\_\_

Purchased From \_\_\_\_\_

Date Purchased \_\_\_\_\_

Model No. \_\_\_\_\_

Serial No. \_\_\_\_\_

**It is the purchaser and/or operator's responsibility to....**

- I Read and understand the information contained in this manual.**
- I Operate, lubricate, assemble and maintain the equipment in accordance with all instructions and safety procedures in this manual.**
- I Inspect the equipment and replace or repair any parts that are damaged or worn which under continued operation would cause damage, wear to other parts, or cause a safety hazard.**
- I Return the equipment or parts to the authorized King Kutter dealer, from where it was purchased, for service or replacement of defective parts that are covered by warranty. (The King Kutter Factory or an Authorized King Kutter Dealer may inspect equipment or parts before warranty claims are honored.)**

# CONTENTS

<b>ITEM</b>	<b>PAGE</b>
Safety .....	6
Safety Training .....	8
Operational Safety.....	10
Transportation & Storage Safety .....	13
Safety Decals .....	14-18
Safety Signs Locations .....	19
Attach To Tractor .....	20
Blade Replacement .....	22
Operating Instructions .....	23
Lubrication Schedule .....	23
PTO Shaft Parts .....	24
Replacement Parts.....	26
Kutter Head Replacement Parts.....	28
Warranty .....	30

## SAFETY

READ AND FOLLOW THE INSTRUCTIONS IN THIS MANUAL AND ESPECIALLY IN THE SAFETY SECTION. FAILURE TO DO SO CAN RESULT IN SERIOUS INJURY OR DEATH.

TAKE NOTE! THIS SAFETY ALERT SYMBOL FOUND THROUGHOUT THIS MANUAL IS USED TO CALL YOUR ATTENTION TO INSTRUCTIONS INVOLVING YOUR PERSONAL SAFETY AND THE SAFETY OF OTHERS.



THIS SYMBOL MEANS  
**ATTENTION!**  
**BECOME ALERT!**  
YOUR SAFETY IS INVOLVED

### SIGNAL WORDS:

The signal words **DANGER**, **WARNING** and **CAUTION** are used with the safety messages in this manual and with each safety signs. They are defined as follows:

**DANGER:** Indicates an immediate hazardous situation that, if not avoided, could result in serious injury or death. This signal word is to be limited to the most extreme situations typically for machine components that, for functional purposes, cannot be guarded.

**WARNING:** Indicates a potentially hazardous situation that, if not avoided, could result in serious injury or death, and includes hazards that are exposed when guards are removed. It may also be used to alert against unsafe practices.

**CAUTION:** Indicates a potentially hazardous situation that, if not avoided, may result in minor or moderate injury. It may also be used to alert against unsafe practice.

If you have any questions not answered in this manual or require additional copies or the manual is damaged, please contact your dealer or King Kutter, Inc. P.O. Box 1200 Winfield, AL 35594 (205) 487-3202 or [www.kingkutter.com](http://www.kingkutter.com)

## EQUIPMENT SAFETY GUIDELINES



- I Safety of the operator and bystanders is one of the main concerns in designing and developing a stump kutter. However, every year accidents occur which could have been avoided by a few seconds of thought and a more careful approach to handling equipment. You, the operator, can avoid many accidents by observing the following precautions and insist those working with you, or for you, follow them.
- I In order to provide a better view, certain photographs or illustrations in this manual may show an assembly with a safety shield removed. However, equipment should never be operated in this condition. Keep all shields & guards in place. If shield or guard removal becomes necessary for repairs, replace the shield prior to use.
- I Replace any safety sign that is not readable or is missing. Copies of such safety signs are shown in this manual.
- I Never use alcoholic beverages or drugs that can hinder alertness or coordination while operating this equipment. Consult your doctor about operating this machine while taking prescription medications.
- I **Under no circumstances should children under the age of 18 be allowed to work with this equipment. Do not allow persons to operate or assemble this unit until they have read this manual and have developed a thorough understanding of the safety precautions and of how it works.** Review the safety instructions with all users annually.
- I This equipment is dangerous to children and persons unfamiliar with its operation. The operator should be a responsible, properly trained and physically able person familiar with farm machinery and trained in this equipment's operations. If the elderly are assisting with farm work, their physical limitations need to be recognized and accommodated.
- I Use a tractor equipped with a Roll Over Protective System and seat belts. (ROPS)
- I Never exceed the limits of a piece of machinery. If its ability to do a job, or to do so safely, is in question- **DON'T TRY IT.**
- I Do not modify the equipment in any way. Unauthorized modification could result in serious injury or death and may impair the function and life of the equipment.
- I In addition to the design and the confirmation of this implement, including safety signs and safety equipment, hazard control and accident prevention are dependent upon the awareness, concern, prudence, and proper training of personnel involved in the operation, transport, maintenance, and storage of the machine. Refer also to safety messages and operation instruction in each of the appropriate sections of the tractor and post hole digger manuals. Pay close attention to the safety signs affixed to the tractor and the stump kutter.

## SAFETY TRAINING



- I Safety is a primary concern in the design and manufacture of our product. Unfortunately, our efforts to provide safe equipment can be wiped out by a single careless act of an operator or bystander.
- I In addition to the design and configuration of equipment, hazard control and accident prevention are dependent upon the awareness, concern, prudence and proper training of personnel involved in the operation, transport, maintenance and storage of this equipment.
- I It has been said, “ The best safety device is an informed, careful operator.” We ask you to be that kind of operator. It is the operator’s responsibility to read and understand all safety and operating instructions in the manual and to follow them. Accidents can be avoided.
- I Working with unfamiliar equipment can lead to careless injuries. Read this manual, and the manual for your tractor, before assembly or operating, to acquaint yourself with the machines. If this machine is used by any person other than you, or is loaned or rented, it is the stump kutter owner’s responsibility to make certain that owner’s manual be available to the operator prior to operating and that the operator:
  - 1- Reads and understands the operator’s manuals.
  - 2- Is instructed in safe and proper use.
- I Know your controls and how to stop tractor, engine, and the stump kutter quickly in an emergency. Read this manual and the one provided with your tractor.
- I Train all new personnel and review instructions frequently with existing workers. Be certain only a properly trained and physically able person will operate the machinery. A person who has not read and understood all operating and safety instructions is not qualified to operate the machine. An untrained operator exposes himself and bystanders to possible serious injury or death. If the elderly are assisting with stump removal, their physical limitations need to be recognized and accommodated.



## PREPARATION



- I Never operate the tractor and stump kutter until you have read and completely understand this manual, the Tractor Operator's Manual, and each of the safety messages found on the safety signs on the tractor and stump kutter.
- I Personal protection equipment including hardhat, safety glasses, safety shoes, and gloves are recommended during assembly, installation, operation, adjustment, maintenance, repairing, removal, or moving the implement. Do not allow long hair, loose fitting clothing, or jewelry to be around equipment.
- I **PROLONGED EXPOSURE TO LOUD NOISE MAY CAUSE PERMANENT HEARING LOSS!** Tractors with or without stump kutter attached can often be noisy enough to cause permanent, partial hearing loss. We recommend that you wear hearing protection on a full-time basis if the noise in the operator's position exceeds 80 db. Noise over 80 db on a long-term basis can cause severe hearing loss. Noise over 90 db adjacent to the operator over a long-term basis may cause permanent, total hearing loss. **NOTE:** Hearing loss from loud noise (from tractors, chain saws, radios, and other such sources close to the ear) is cumulative over a lifetime without hope of natural recovery.
- I Operate the stump kutter only with a tractor equipped with an approved Roll-Over-Protective System (ROPS). Always wear your seat belt. Serious injury or even death could result from falling off the tractor — particularly during a turnover when the operator could be pinned under the ROPS or the tractor.
- I Operate only in daylight or good artificial light.
- I Ensure the post stump kutter is properly mounted, adjusted and in good operating condition.
- I Ensure that all safety shielding and safety signs are properly installed and in good condition.

## STARTING AND STOPPING SAFETY



- I Check the tractor master shield over the PTO stub shaft. Make sure it is in good condition and fastened securely to the tractor. Purchase a new shield if old shield is damaged or missing.
- I All tractors that are not equipped with a "live" power takeoff (PTO) need to be equipped with an over-running PTO clutch. These are available through most farm equipment stores. **NOTE:** The addition of an over-running PTO clutch may change the length of the PTO driveline required. Pay extra attention to the instructions on the PTO driveline Installation. Be sure that the driveline system guarding is adequate.
- I The stump kutter operating power is supplied from the tractor PTO. Refer to your tractor manual for PTO engagement and disengagement instructions. Know how to stop tractor and check stump kutter quickly in case of an emergency.

## OPERATIONAL SAFETY



This product is designed to remove stumps when attached to the 3-point linkage system and PTO of a tractor. It is **not** intended for any other use! Using the product for anything other than removing stumps could result in serious injury or death!

- I The use of this equipment is subject to certain hazards that cannot be protected against by the mechanical means or product design. All operators of this equipment must read and understand this entire manual, paying particular attention to safety and operating instructions, prior to using. If there is something in this manual you do not understand, ask your supervisor, or your dealer, to explain it to you.
- I Most accidents occur because of neglect or carelessness. Keep all helpers and bystanders at least 50 feet from an operating stump kutter. Only properly trained people should operate this machine.
- I When machine is operated in populated area **operation must be stopped when anyone comes within 50 feet.**
- I The majority of the accidents involve entanglement on the driveline and operators being knocked off the tractor by low hanging limbs. Accidents are most likely to occur with machines that are loaned or rented to someone who has not read the owner's manual and is not familiar with a stump kutter and or a tractor.
- I The stump kutter is designed for use only on tractors with **540-RPM** power take off.
- I Install and secure all guards and shields before starting or operating. The driveline guards and tractor shields should be used and maintained in good working condition. They should be inspected carefully, at least daily, for missing or broken cable, chain links, shields, or guards. (Worn items must be replaced at once to reduce possibility of injury)
- I Disengage power takeoff (PTO) and place transmission in neutral before attempting to start engine.
- I Many varied objects, such as wire, cable, rope, or chains, can become entangled in the operating parts of the stump kutter These items could then swing at great velocities. Such a situation is extremely hazardous. Inspect the area for such objects before stump cutting. Remove any like objects from the site.
- I Never allow the cutting head to contact such items. Never assume an area is clear. **Always Check!**

## OPERATIONAL SAFETY *continued...*



- I Always stop the tractor, disengage PTO, set brake, shut off the tractor engine, remove the ignition key, lower implement to the ground and allow cutting head to come to a complete stop before dismounting tractor. Never leave equipment unattended with the tractor running.
- I Never place hands or feet close to stump kutter with tractor engine running or before you are sure all motion has stopped. Stay clear of all moving parts.
- I Do not reach or place any part of your body close to equipment until it is blocked securely.
- I Do not allow riders on the tractor at anytime. There is no safe place for any riders.
- I Do not operate unless all personnel, livestock, and pets are at least 50 feet away to prevent injury.
- I The rotating parts of this machine have been designed and tested for rugged use. However, they could fail upon impact with heavy, solid objects such as steel guardrails and concrete abutment. Cutting head impact could cause the broken objects to be thrown outward. To reduce the possibility of property damage, serious injury, or even death, never allow the auger to contact such obstacles.
- I Stop the stump kutter and tractor immediately upon striking an obstruction. Turn engine off, remove key, inspect and repair any damage before resuming operation.
- I Stay alert for uneven terrain, rocks, and roots and other hidden hazards. Keep away from drop-offs and hazards that could cause roll over. Use extreme care and maintain minimum ground speed when transporting or operating on hillsides, over rough ground and when operating close to ditches or fences. Be careful and slow down when turning sharp corners and changing direction on slopes. Do not start or stop suddenly on slopes. Avoid operation on steep slopes. In extremely uneven terrain, rear wheels weights, front tractor weight, and/or tire ballast should be used to improve stability.
- I Always check tractor manual for proper use on slopes.
- I When using a unit, a minimum 20% of tractor and equipment weight must be on tractor front wheels. Without this weight, tractor could tip over, causing personal injury or death. The weight may be attained with a front- end loader, front wheel weights, ballast in the tires or front tractor weights. When attaining a minimum 20% of tractor and equipment weight on the front wheels, you must not exceed the ROPS weight certification. Weigh the tractor and equipment. **Do not guess or estimate!**

## OPERATIONAL SAFETY *continued...*



- I Before removing a stump contact your local utility companies (electrical, telephone, gas, water, sewer and others) so that they can mark the location of any underground services in the area. Be sure to ask just how close you can work to the marks they positioned. Avoid contact with any overhead utility lines or electrically charged conductors.
- I Do not operate the stump kutter when the cutting head is more than 18" above the ground level or the driveline may bind causing injury to the operator and damage to the equipment.
- I Do not attempt to manually guide the stump kutter for location or to manually push down on the equipment while it is in operation. Do not put anything or anyone on the equipment for the purpose of adding weight to the unit. Objects and people can be thrown or become entangled in the unit.

## **TRANSPORT SAFETY**



- I Comply with state and local laws governing highway safety and movement of farm machinery on public roads.
- I The use of flashing amber lights is acceptable in most localities. However, some localities prohibit their use. Local laws should be checked for all lighting and marking requirements.
- I At all times, when driving the tractor and equipment on the road or highway under 20mph (32kph) use flashing amber warning lights and a slow moving vehicle (SMV) identification emblem. Do not exceed 20 mph (32 kph). Reduce speed on rough roads and surfaces.
- I Plan your route to avoid heavy traffic.
- I Always install transport locks, pins or brackets before transporting.
- I Do not drink and drive.
- I Be a safe and courteous driver. Always yield to oncoming traffic in all situations, including narrow bridges, intersections, etc. Watch for traffic when operating near or crossing roadways.
- I Turn curves or go up or down hills only at a low speed and at a gradual steering angle. Make certain that a least 20% of the tractor's weight is on the front wheels to maintain safe steerage. Slow down on rough or uneven surface. Always check tractor manual for proper use on slopes.
- I Be careful when turning sharp corners.
- I Never allow riders on either tractor or stump kutter.

## **STORAGE SAFETY**



- I Following operation, or when unhooking the stump kutter, stop the tractor, set the brakes, disengage the PTO, shut off the engine and remove the ignition keys.
- I Store the unit in an area away from human activity.
- I Do not park equipment where it can be exposed to direct contact to livestock for long periods of time. Damage and livestock injury could result.
- I Make sure all parked machines are on a hard, level surface and engage all safety devices.

## SAFETY SIGNS



1



2

 **DANGER**

DO NOT ATTACH THIS IMPLEMENT OR ATTEMPT TO OPERATE UNTIL YOU HAVE READ AND UNDERSTOOD ALL INSTRUCTIONS IN THE OWNERS MANUAL. IF AN OWNERS MANUAL IS NOT AVAILABLE PLEASE CONTACT YOUR DEALER.

3

 **WARNING**



**PINCH POINT**

4

**PATENT  
PENDING**

5

**! DANGER**



**CONSULT TRACTOR OWNERS  
MANUAL FOR SAFE  
OPERATION ON SLOPE**

6

**! WARNING**



**STOP**

STOP CUTTING HEAD BY DISENGAGING PTO, THEN STOP ENGINE AND REMOVE KEY BEFORE DISMOUNTING TRACTOR. READ OPERATORS MANUAL BEFORE SERVICING EQUIPMENT.



7

**IMPORTANT**

**CHECK OIL IN GEAR BOX AND  
GREASE FITTINGS BEFORE USE.  
"CONSULT OWNERS MANUAL FOR  
LUBRICATING AND OPERATING INSTRUCTIONS."**

8

**! DANGER**



**CLEAR FOREIGN  
OBJECTS FROM STUMP**

9



# NOTICE

Your King Kutter equipment has been designed and built with your safety in mind, but a tractor and its attachments are unable to control their own operation, or to choose the environment in which they work. The ultimate responsibility for safe operation lies with you, the operator.

10

## DANGER

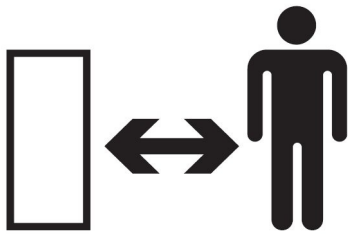

**STAY BACK  
50 FEET**

11

## DANGER



### Rotating Parts Hazard

Keep Away To Prevent Serious Injury or Death from Rotating Parts:

- Read and understand owners manual before operating.
- Do not operate without all shields and guards in place.
- Keep away from cutting head when engine is running.

12

## DANGER



**DO NOT RIDE OR  
HANG ON EQUIPMENT**

13

**⚠ DANGER**

<p style="text-align: center;"><b>ROTATING DRIVELINE</b> CONTACT CAN CAUSE DEATH <b>KEEP AWAY!</b> DO NOT OPERATE WITHOUT -</p>	
<ul style="list-style-type: none"> <li>• All driveline guards, tractor and equipment shields in place.</li> <li>• Driveline securely attached at both ends.</li> <li>• Driveline guards that turn freely on driveline</li> </ul>	

14



7 03996 00518 8

**MODEL NO.**

**DESCRIPTION**

**SN# XXXXXXXXXX**

15

**Operators Manuals & Parts**

**are available from**

**your dealer, or**

**King Kutter, INC.**

**Winfield, AL 35594**

**(205) 487-3202**

**or**

**[www.kingkutter.com](http://www.kingkutter.com)**

16

# SAFETY SIGNS LOCATIONS

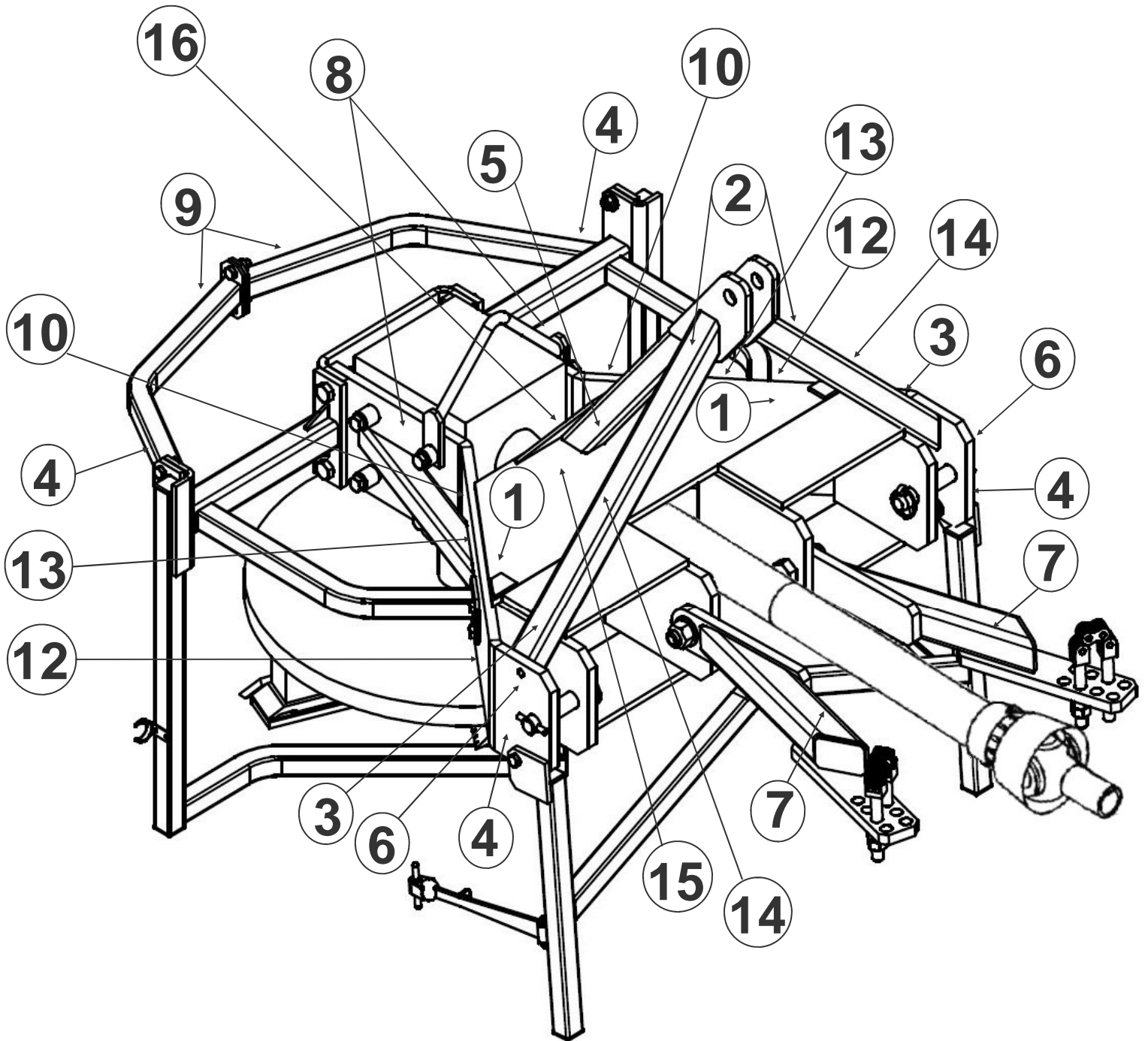

## ATTACHING TO TRACTOR

1. Connect tractor lift arms to stump kutter with Cat. II pins.



### WARNING

Never stand between tractor and stump kutter while backing up tractor to the hitch.



2. Connect hydraulic top link from tractor to top of stump kutter with Cat. II top link pin.
3. Remove roller chains with threaded legs & nuts from the stabilizer arms and bring arms up to tractor lift arms.
4. Place roller chain over tractor lift arms & drop threaded ends through appropriate holes in stabilizer arms.
5. Torque nuts to 400 ft. lbs. underneath stabilizer arms to hold them tight against lift arms.
6. Lock nuts in place by using a second nut as a jam nut.

### LUBRICATE PTO INNER AND OUTER TUBES

7. Separate PTO drive shaft. Use a good TYPE/Grade II tube grease and put a light coat on the drive shaft halves. Then reinsert male shaft into female shaft drive tube, then grease fittings on U-joints.
8. Snap tractor end yoke on tractor PTO.
9. Attach chain on outer driveline shield to tractor and the one on inner driveline shield to stump kutter. This is very important for operator safety and failure to do so may result in injury or death!
10. Lift stump kutter slightly off ground and rotate rear stand back and over stump kutter until it rests on top of the frame.
11. Lift up on the front stand by pulling up and back on the rubber latch and fasten it in the catch on the rear stand. Make sure to latch the opposite side likewise.

## ATTACHING TO TRACTOR *continued....*

12. Raise and lower the stump kutter through it's complete operation arch and check that nothing interferes with the operation. If anything interferes, make the proper three-point adjustments.

### CHECK DRIVELINE FOR MINIMUM OVERLAP

11. (SEE FIGURE BELOW) With PTO shaft hooked to tractor & stump kutter raise and lower implement to find PTO's longest extended point and at that point measure length of cover of the PTO at (A), transfer the measurement of (A) to (B), mark cover at the end of measurement of (B), then make sure measurement of (C) is at least 6".

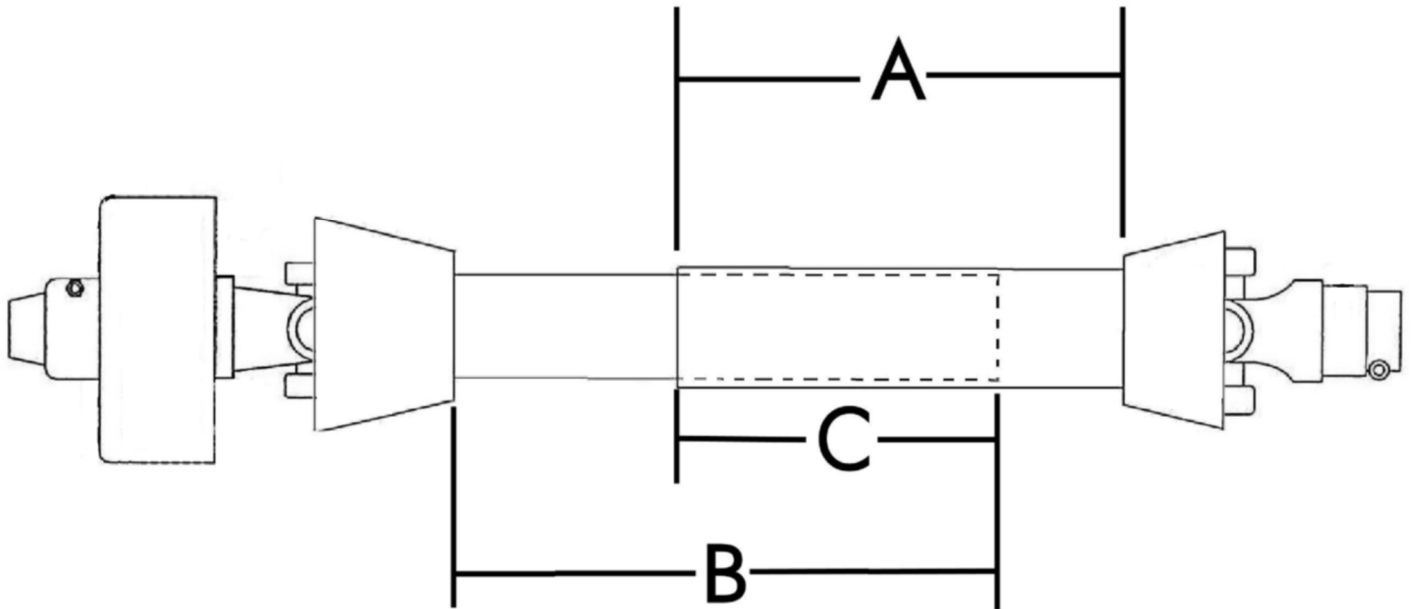

## BLADE REPLACEMENT

1. Always stop the tractor, disengage PTO, set brake, shut off the tractor engine, remove the ignition key, lower implement to the ground and allow cutting head to come to a complete stop before dismounting tractor. Never leave equipment unattended with the tractor running.

### WARNING

**DO NOT ATTEMPT TO PERFORM ANY SERVICE OR MAINTENANCE ON STUMP KUTTER WHILE SUSPENDED ON TRACTOR LIFT ARMS. ALWAYS SET STUMP KUTTER ON PARKING STANDS BEFORE ANY SERVICE.**



2. Release rubber latches on both sides, allowing front stand to rotate to the ground.
3. Rotate rear stand up over frame and back down to the ground.
4. Start tractor and raise stump kutter so that rear stand rotates underneath the cutting head and then lower the stump kutter, adjusting position as necessary so that it sits securely on the stands.
5. Turn off tractor and remove key before dismounting for the next steps.
6. Clean out any dirt or obstructions in the countersunk socket head bolts and pockets for access to the nuts that hold the blades in place.
7. Remove nuts and bolts with correct sized socket and allen wrench.
8. Clean off any dirt from pad holding blade.
9. Install new blade with new bolts and nuts, torquing to 100 ft. lbs.

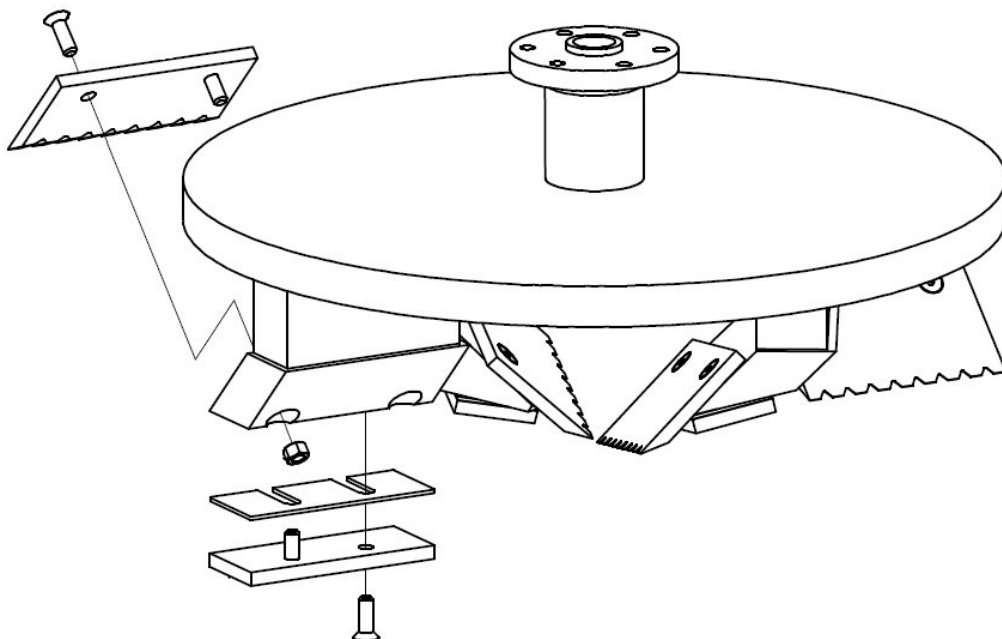

# LUBRICATION SCHEDULE

## SHIPPED WITH OIL IN GEAR BOX

SHIPPED WITHOUT GREASE IN GREASE FITTINGS.

- **UNIT MUST BE SERVICED BEFORE USING.\***
- When Adding Oil Use Multi-Purpose Gear Oil (I.E. S.A.E. 80w/90 or S.A.E. 85w/140 Multi-purpose gear oil) in Gearbox.
- For all Grease Fittings, the PTO shaft tube and U-joints, use TYPE/Grade II tube grease.

Check gearbox periodically (approx. every 50 hours) to maintain correct oil level.

Universal joints to be greased every 8 hours. Tube and shaft should be greased every 100 hours or every season, which ever comes first.

## OPERATING INSTRUCTIONS

1. Inspect stump to be removed and clear any foreign objects from around it to prevent injury from thrown objects..
2. With stands in the operating position and both rubber latches fastened, raise stump kutter over stump. If stump is too tall, cut it down to about 12” in height, using a chain saw.
3. Set brake or use park on transmission.
4. Engage PTO and set engine to normal operating rpm.
5. Lower stump kutter onto stump and allow the weight of the stump kutter to provide downward pressure as it cuts the stump.
6. Use hydraulic top link to keep the stump kutter level as it cuts the stump.
7. Depending on the size of the stump, it may be necessary to reposition the cutting head in order to completely remove the stump.
8. If the safety clutch in the driveline disengages, it will cause a distinctive clacking sound to alert the operator. When this occurs, simply lift the stump kutter and reduce engine speed until the clutch re-engages and the sound stops
9. Return engine to normal operating rpm and lower the cutting head back onto the stump to resume operation.
10. Continue cutting and repositioning if necessary, until the stump is removed down to the desired depth.

# SK SERIES 5 PTO 147224

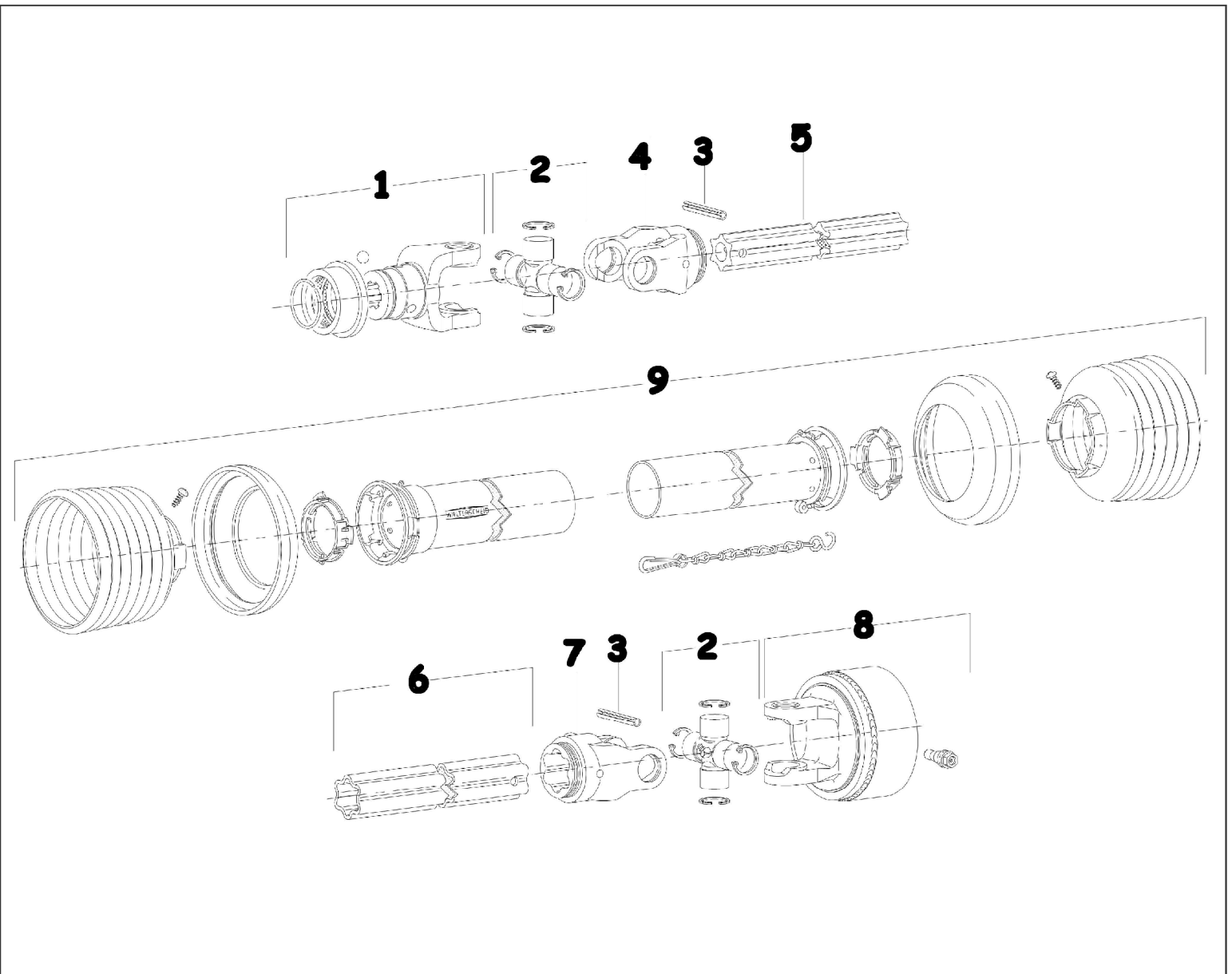

Ref. No.	Part Name	Part No.
1	YOKE	
2	CROSS KIT	
3	ROLL PIN (PK 2)	
4	INBOARD YOKE S4	
5	INNER SHAFT	
6	OUTTER SHAFT	
7	INBOARD YOKE S5	
8	CAM-TYPE CUT-OUT CLUTCH	
9	COMPLETE SHIELD	



# NOTES:

# Parts Diagram

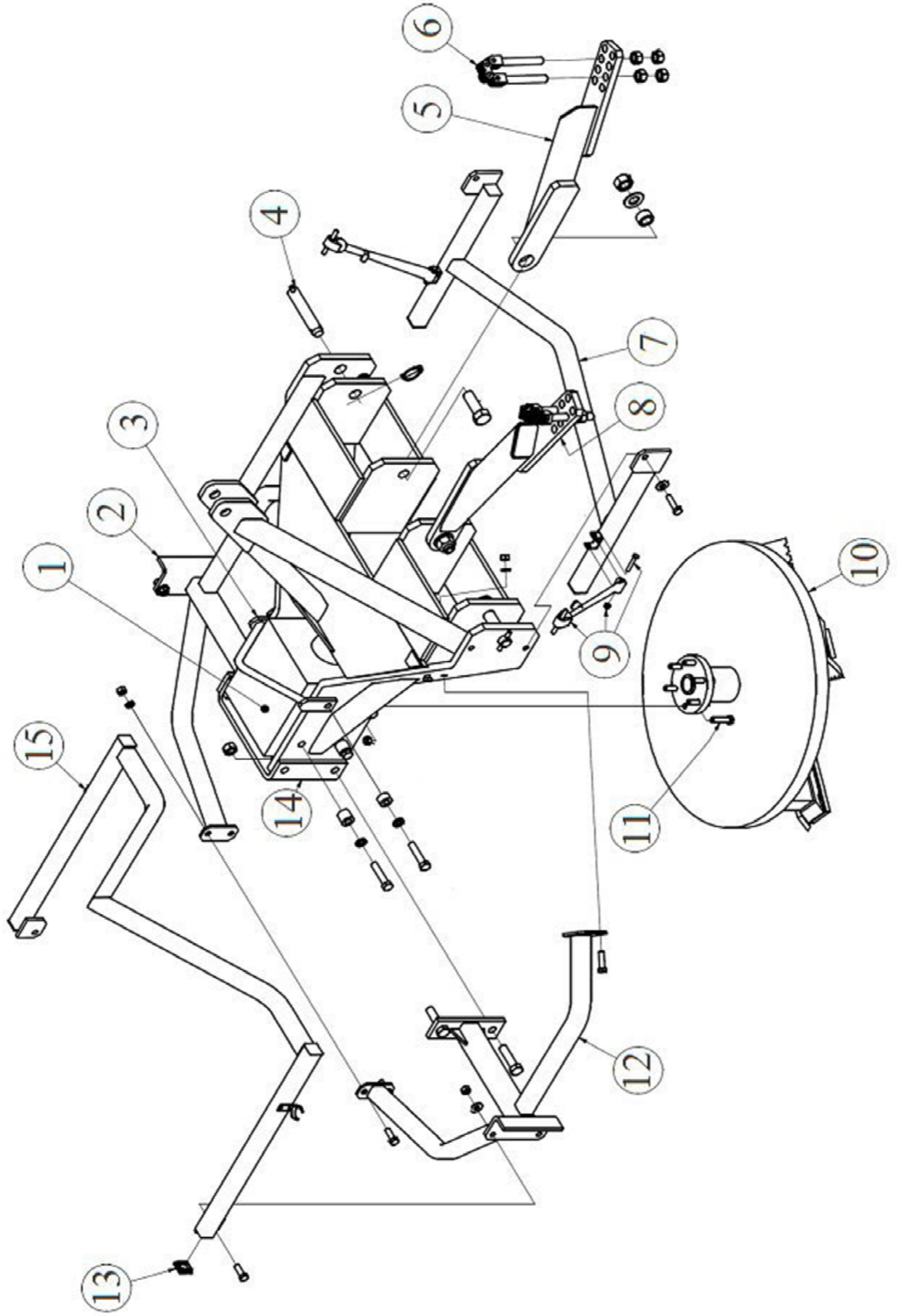

**STUMP CUTTER PARTS**

Ref. No.	Part Name	Part Number
1	HR 600 GEARBOX	
2	STAND ARM WELDMENT LH	
3	LIFT WELDMENT	
4	STRAIGHT LIFT PIN CAT II (PK. 2)	
5	STABILIZER LEG LT	
6	LEAF CHAIN WITH ANCHOR BOLTS (PK. 2)	
7	STAND WELDMENT	
8	STABILIZER LEG RT	
9	RUBBER LATCH (PK. 2)	
10	BLADE HEAD ASSEMBLY	
11	BLADE HEAD BOLT PKG.	
12	STAND ARM WELDMENT RH	
13	PLASTIC END CAP ( PK. 4)	
14	BACK BAR	
15	STAND LEG WELDMENT	

# Head Parts Diagram

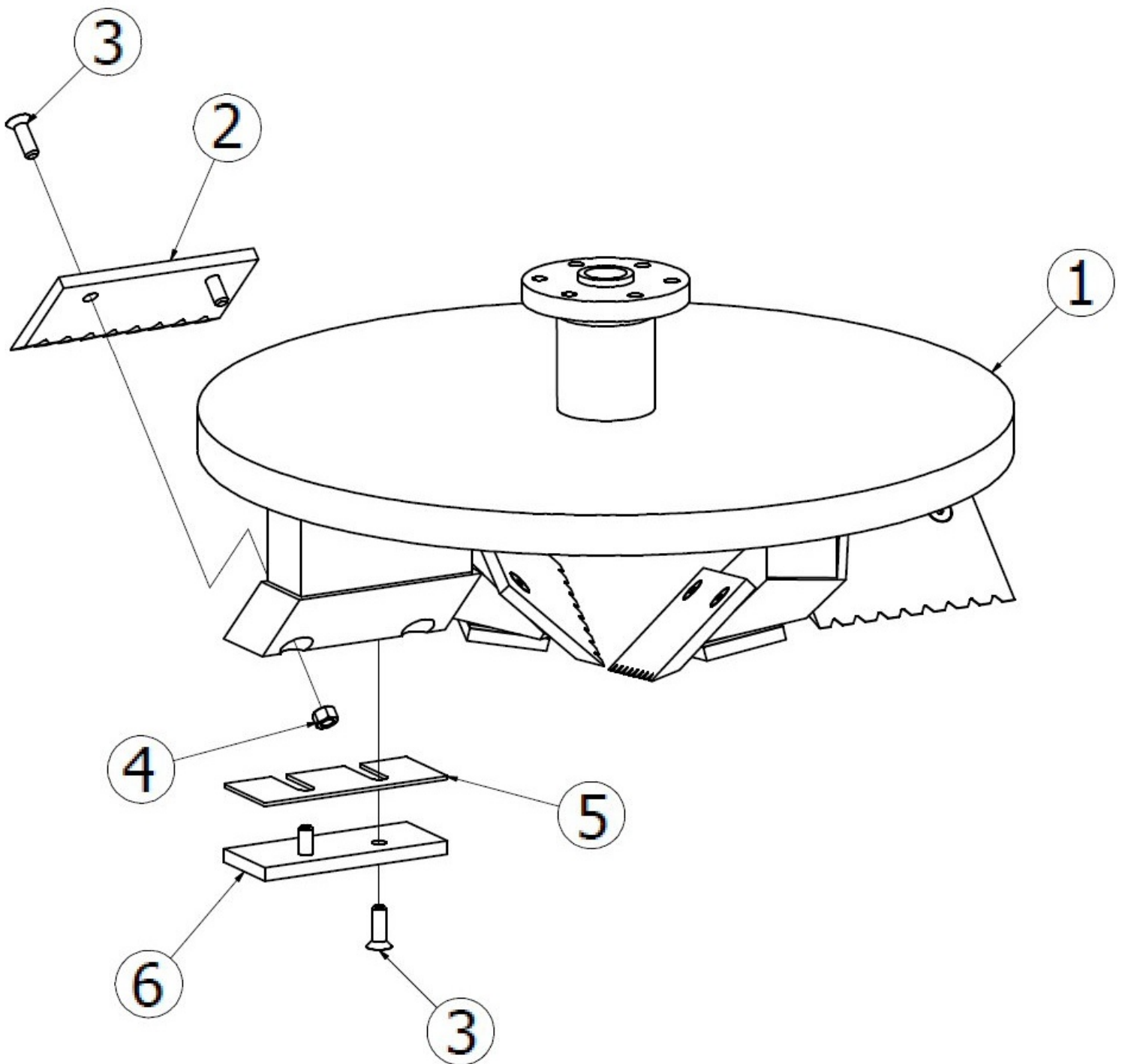





### **1. Limited Warranty.**

King Kutter, Inc. ("King Kutter"), P.O. Box 1200, Winfield, Alabama 35594, warrants to the original retail purchaser ("Purchaser") that the product that is the subject of this sale is free from defects in material and workmanship at the time of sale.

Under this warranty, King Kutter will repair the defective product free of charge to the Purchaser, with either new or used and reconditioned replacement parts. All warranty service will be performed at service centers designated by King Kutter. If King Kutter is unable to repair the product to conform to the warranty after a reasonable number of attempts, King Kutter will provide, at its option, one of the following: (a) a replacement for the product or, (b) a full refund of the purchase price. Repair, replacement, or refunds are the Purchaser's EXCLUSIVE remedies against King Kutter under this limited warranty. King Kutter will not be liable for any special, incidental or consequential damages based upon breach or warranty, breach of contract, negligence, strict tort liability, or any other legal theory. Such damages include, but are not limited to, loss of profits, loss of savings or revenue, loss of use of the product or any associated equipment, cost of capital, cost of any substitute equipment, facilities or services, down time, the claims of third parties including customers, and injury to property. These limitations also apply, to the extent allowed by law, to personal injury.

The purchaser must notify the Seller in writing of any defect in material or workmanship within one (1) year following the date of purchase. If the equipment is used for commercial purposes, the Purchaser must notify the Seller in writing of any defect in material or workmanship within ninety (90) days following the date of purchase. In no event will King Kutter be liable under this warranty unless written notice is received by the Seller within one (1) year from the date of original retail sale.

### **2. Warranty of Title.**

King Kutter warrants that it transfers a good title to the product free of any encumbrances, and free of the rightful claim of any third party for infringement of patent or copyright.

### **3. What is Not Covered by This Limited Warranty.**

King Kutter will not be responsible for damage to or failure in the product which results from accident, misuse, abuse, neglect, installation of attachments not provided by King Kutter, modifications to the product, or damage caused by use of the product for purposes other than those for which it was designed.

### **4. No Other Warranties.**

Unless modified in writing and signed by both parties, this agreement is understood to be the complete and exclusive agreement and warranty between King Kutter and Purchaser, superseding all prior agreements, oral and written, and all other communication between King Kutter and Purchaser related to the subject matter of this agreement.

THIS LIMITED WARRANTY IS IN LIEU OF ALL OTHER WARRANTIES, EXPRESS OR IMPLIED, INCLUDING, BUT NOT LIMITED TO, THE IMPLIED WARRANTY OF MERCHANTABILITY AND THE IMPLIED WARRANTY OF FITNESS FOR A PARTICULAR PURPOSE. No employee of King Kutter nor anyone else is authorized to make any warranty or representation in addition to or different from those made in this agreement.

### **5. Allocation of Risk.**

This agreement allocates the risk of product failure between King Kutter and the Purchaser. This Allocation is recognized by both parties as reflected in the price of the goods. The Purchaser acknowledges that he or she has read this agreement, understands it, and is bound by its terms.