

FREE FLOATING REAR DISCHARGE FLEX HITCH FINISHING MOWER

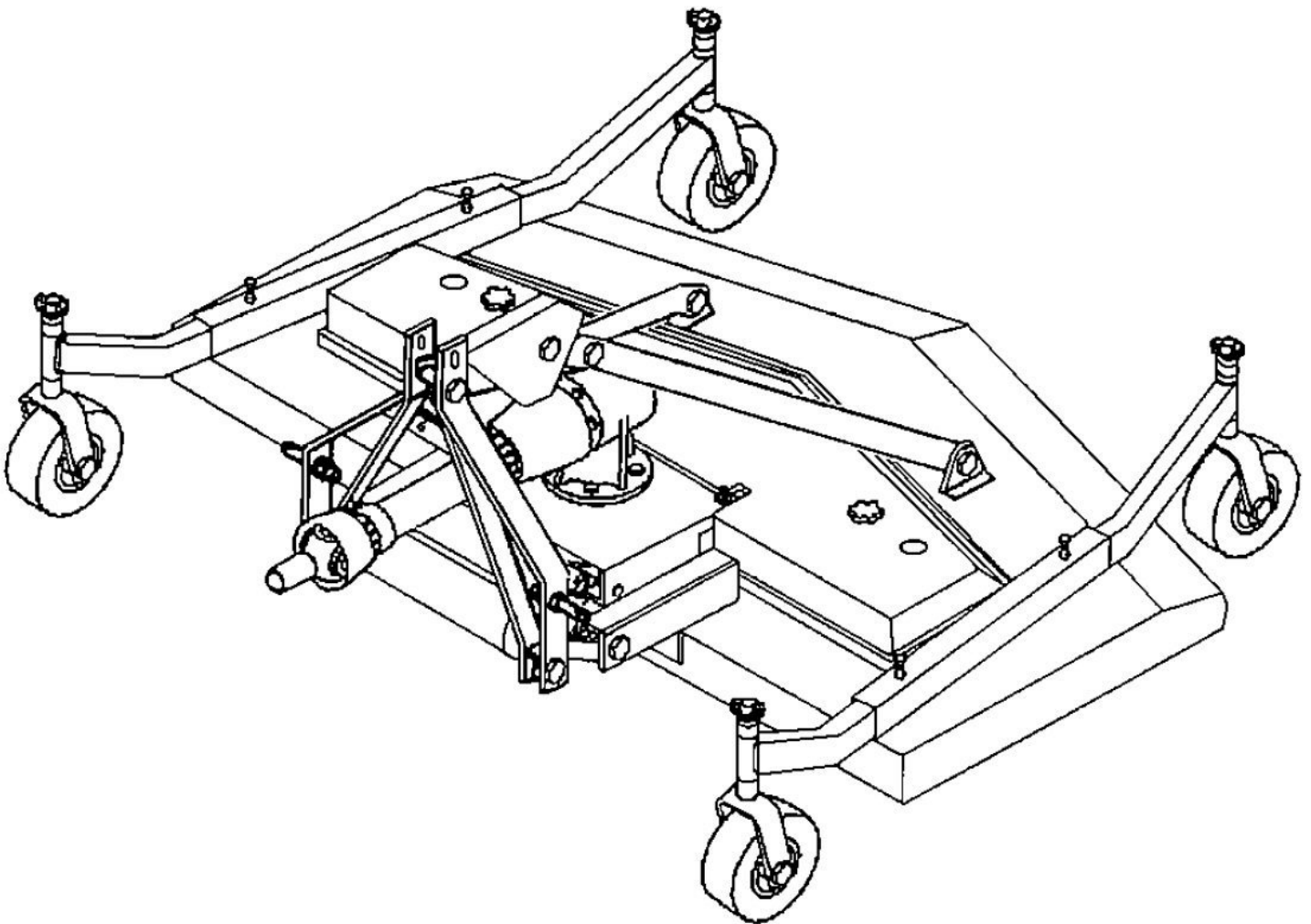

MARCH 2024

TO THE PURCHASER

This manual contains valuable information about your new King Kutter Flex Hitch Rear Discharge Finishing Mower. It has been carefully prepared to give you helpful suggestions for operating, adjusting, servicing and ordering repair parts.

Keep this manual in a convenient place for quick and easy reference. Study it carefully. You have purchased a dependable and sturdy mower, but only by proper care and operation can you expect to receive the service and long life designed and built into it.

Sometime in the future your mower may need new parts to replace those that are worn or broken. If so, go to your dealer and provide him with the model and part number.

Customer Information

Name _____

Purchased From _____

Date Purchased _____

Model No. _____

Serial No. _____

It is the purchaser and/or operator's responsibility to....

- I Read and understand the information contained in this manual.**
- I Operate, lubricate, assemble and maintain the equipment in accordance with all instructions and safety procedures in this manual.**
- I Inspect the equipment and replace or repair any parts that are damaged or worn which under continued operation would cause damage, wear to other parts, or cause a safety hazard.**
- I Return the equipment or parts to the authorized King Kutter dealer, from where it was purchased, for service or replacement of defective parts that are covered by warranty. (The King Kutter Factory may inspect equipment or parts before warranty claims are honored.)**
- I Payment of all costs incurred by the dealer for traveling to or transporting the equipment for warranty inspection and or claims.**

CONTENTS

ITEM	PAGE
Safety	6
Assembly Instructions	8
Before Putting Into Service	10
Safety Training	11
Transportation Safety	15
Attaching To Tractor.....	16
Sizing PTO	18
Operating Instructions	19
Maintenance.....	21
5-6-7 FT. Belt Replacement.....	22
4 FT. Belt Replacement	24
Maintenance Safety.....	26
Safety Decal's And Locations	27
Replacement Parts.....	34
PTO Shaft Parts	36
Spindle Unit Parts.....	37
Gearbox Parts	38
PTO Shaft Cover Removal.....	40
Warranty	43

SAFETY

READ AND FOLLOW THE INSTRUCTIONS IN THIS MANUAL AND ESPECIALLY IN THE SAFETY SECTION. FAILURE TO DO SO CAN RESULT IN SERIOUS INJURY OR DEATH.

TAKE NOTE! THIS SAFETY ALERT SYMBOL FOUND THROUGHOUT THIS MANUAL IS USED TO CALL YOUR ATTENTION TO INSTRUCTIONS INVOLVING YOUR PERSONAL SAFETY AND THE SAFETY OF OTHERS.



**THIS SYMBOL MEANS
ATTENTION!
BECOME ALERT!
YOUR SAFETY IS INVOLVED**

SIGNAL WORDS:

The signal words **DANGER**, **WARNING** and **CAUTION** are used with the safety messages in this manual and with each safety signs. They are defined as follows:

DANGER: Indicates an immediate hazardous situation that, if not avoided, could result in serious injury or death. This signal word is to be limited to the most extreme situations typically for machine components that, for functional purposes, cannot be guarded.

WARNING: Indicates a potentially hazardous situation that, if not avoided, could result in serious injury or death, and includes hazards that are exposed when guards are removed. It may also be used to alert against unsafe practices.

CAUTION: Indicates a potentially hazardous situation that, if not avoided, may result in minor or moderate injury. It may also be used to alert against unsafe practice.

If you have any questions not answered in this manual or require additional copies or the manual is damaged, please contact your dealer or King Kutter, Inc.
P.O. Box 1200 Winfield, AL 35594 (205) 487-3202 or www.kingkutter.com

EQUIPMENT SAFETY GUIDELINES



- I Safety of the operator and by standards is one of the main concerns in designing and developing a mower. However, every year accidents occur which could have been avoided by a few seconds of thought and a more careful approach to handling equipment. You, the operator, can avoid many accidents by observing the following precautions and insist those working with you, or for you, follow them.
- I In order to provide a better view, certain photographs or illustrations in this manual may show an assembly with a safety shield removed. However, equipment should never be operated in this condition. Keep all shields in place. If shield removal becomes necessary for repairs, replace the shield prior to use.
- I Replace any safety sign that is not readable or is missing. Location of such safety signs is indicated in this manual.
- I Never use alcoholic beverages or drugs that can hinder alertness or coordination while operating this equipment. Consult your doctor about operating this machine while taking prescription medications.
- I **Under no circumstances should children under the age of 18 be allowed to work with this equipment. Do not allow persons to operate or assemble this unit until they have read this manual and have developed a thorough understanding of the safety precautions and of how it works. Review the safety instructions with all users annually.**
- I This equipment is dangerous to children and persons unfamiliar with its operation. The operator should be a responsible, properly trained and physically able person familiar with farm machinery and trained in this equipment's operations. If the elderly are assisting with farm work, their physical limitations need to be recognized and accommodated.
- I Use a tractor equipped with a Roll Over Protective System and seat belts. (ROPS)
- I Never exceed the limits of a piece of machinery. If its ability to do a job, or to do so safely, is in question- **DON'T TRY IT.**
- I Do not modify the equipment in any way. Unauthorized modification could result in serious injury or death and may impair the function and life of the equipment.
- I In addition to the design and the confirmation of this implement, including safety signs and safety equipment, hazard control and accident prevention are dependent upon the awareness, concern, prudence, and proper training of personnel involved in the operation, transport, maintenance, and storage of the machine. Refer also to safety messages and operation instruction in each of the appropriate sections of the tractor and mower manuals. Pay close attention to the safety signs affixed to the tractor and the finishing mower.

FINISHING MOWER ASSEMBLY INSTRUCTIONS

STEP 1

With finishing mower still in crate, lay flat on a level surface. Remove the top & side sections of the crate, leaving the finishing mower resting on the bottom section. Set aside PTO shaft.

STEP 2

Insert tail wheel arms as shown in Figure E and tighten both the bolt & jam nut.

STEP 3

Raise A – frame assembly (Fig. A & B, Marked #1) forward and swivel brace arms (Marked #2) around toward rear of the mower. Hook the brace arms to the tabs (Marked #3, Fig. C) on the back of the mower with bolts provided.

(Fig. D Fully Assembled.)

STEP 4

Tighten all nuts and bolts.

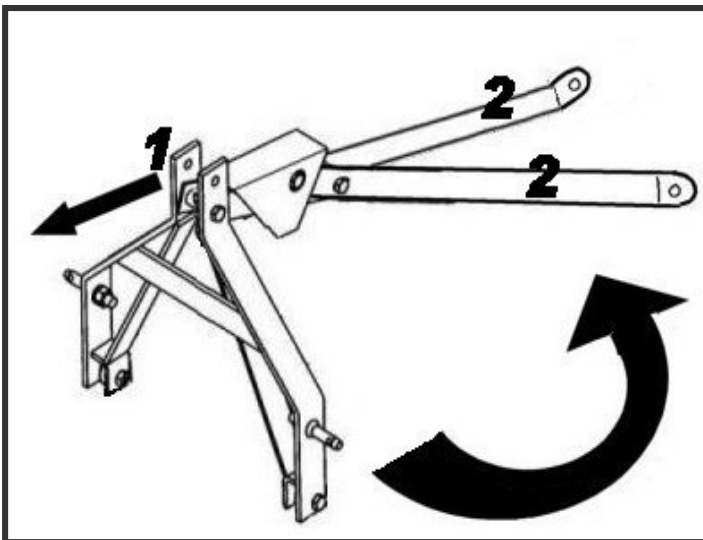

Figure A

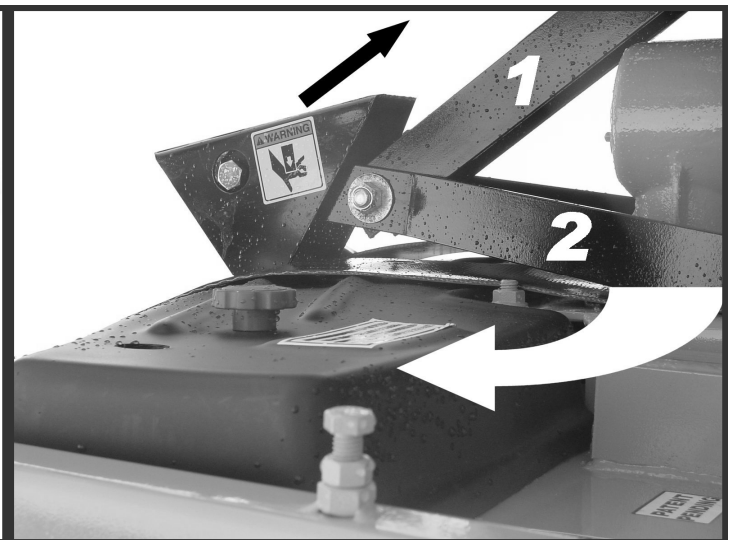

Figure B

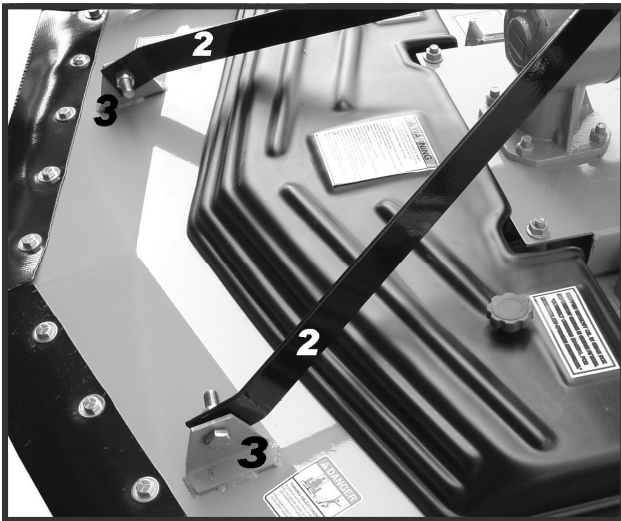

Figure C

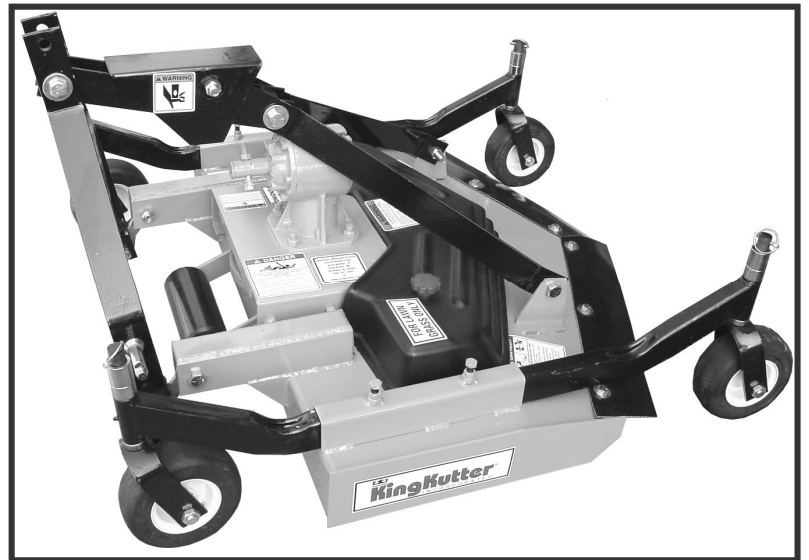

Figure D

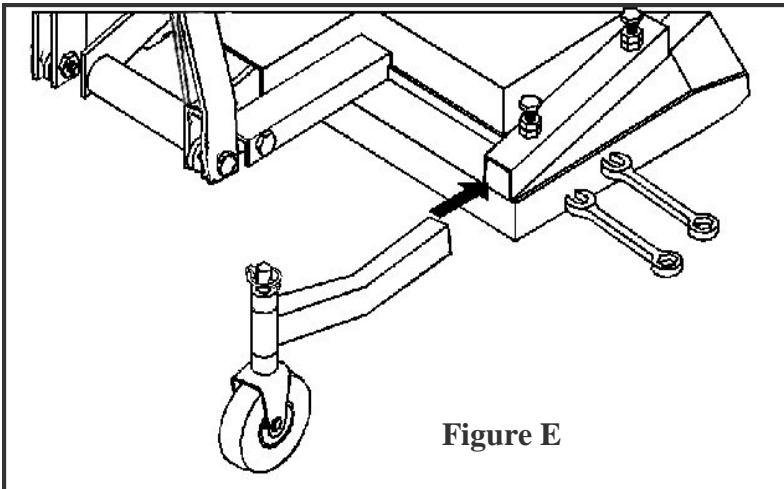

Figure E

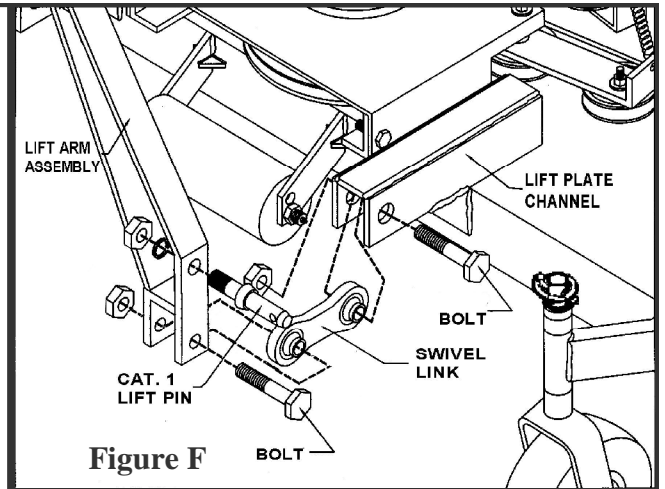
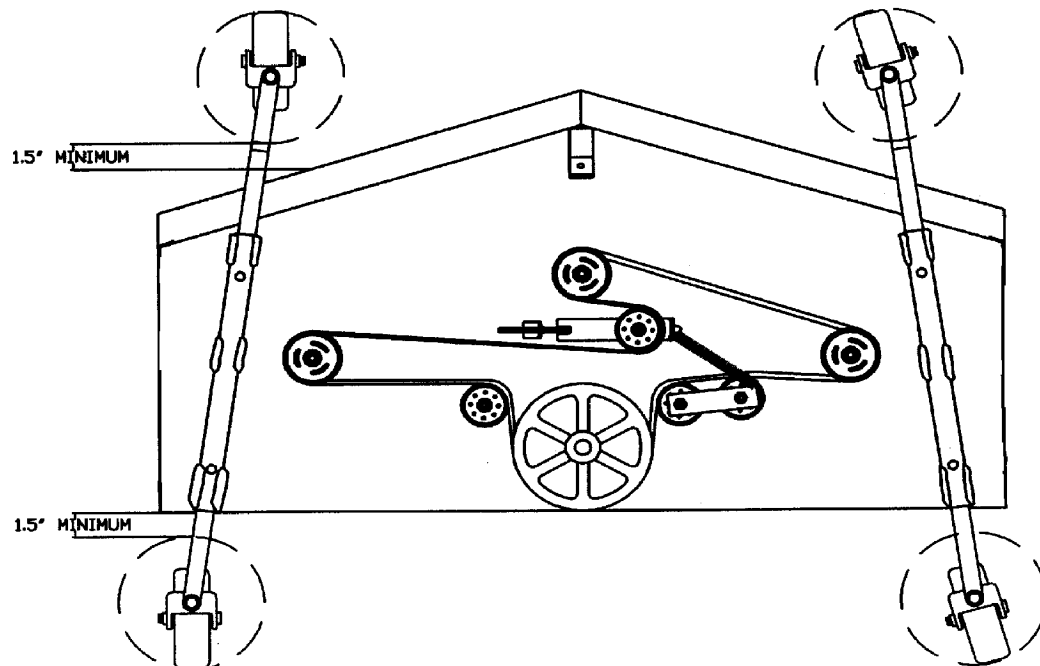

Figure F



BEFORE PUTTING FINISHING MOWER INTO SERVICE

(IMPORTANT-INSTRUCTIONS PRIOR TO START UP)
SHIPPED WITH OIL IN GEARBOX
SHIPPED WITHOUT GREASE IN GREASE FITTINGS.
UNIT MUST BE SERVICED BEFORE USING.

- ***When Adding Oil Use Multi-Purpose Gear Oil (I.E. S.A.E. 80w/90 or S.A.E. 85w/140 Multi-purpose gear oil) in Gearbox.**
- For all Grease Fittings use TYPE/grade II tube grease.

STEP 1 STEP 2

Place finishing mower so that the deck is secure and level.

Remove 1/2" Pipe Plug (Located at top of gearbox) and 1/8" Pipe Plug (located at lower 1/3 of gearbox) if oil comes out lower hole replace lower plug immediately and continue to **Step 4**. If no oil comes out continue to **Step 3**.

STEP 3

Now that you have checked the gearbox lubrication level and it is not level with 1/8" hole, **add one of the multi-purpose gear oils listed above*** through top 1/2" hole until lubrication is level with lower 1/8" hole.

STEP 4

Replace both the 1/2" pipe plug (located at top of gear box) and 1/8" pipe plug (located at lower 1/3 of gear box) and clean away any excess oil.

STEP 5

Fill spindle units (3) with grease until full. There are easy access holes in top cover for greasing spindle units. (Figure C page 21)

STEP 6

Grease wheel axles (4), wheel forks (4), front roller axle (1), and PTO shaft universal joints (2). (Figure C page 21)

STEP 7

Check air pressure in tires, maintain rated PSI listed on the tire at all times.

STEP 8

Check all bolts, nuts and belt to insure they are tight and secure.

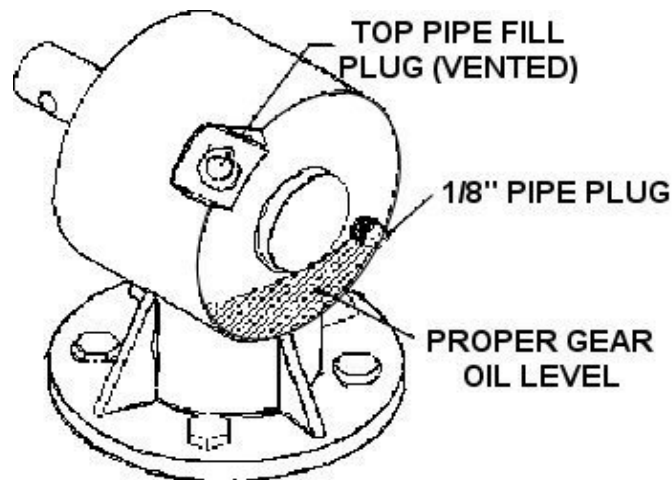

CAUTION:

DO NOT over fill gearbox. This could cause damage to oil seals and can cause permanent damage to the gearbox. This issue will not be covered under warranty.

SAFETY TRAINING



- I Safety is a primary concern in the design and manufacture of our product. Unfortunately, our efforts to provide safe equipment can be wiped out by a single careless act of an operator or bystander.
- I In addition to the design and configuration of equipment, hazard control and accident prevention are dependent upon the awareness, concern, prudence and proper training of personnel involved in the operation, transport, maintenance and storage of this equipment.
- I It has been said, “ The best safety device is an informed, careful operator.” We ask you to be that kind of operator. It is the operator’s responsibility to read and understand all safety and operating instructions in the manual and to follow them. Accidents can be avoided.
- I Working with unfamiliar equipment can lead to careless injuries. Read this manual, and the manual for your tractor, before assembly or operating, to acquaint yourself with the machines. If this machine is used by any person other than you, or is loaned or rented, it is the finishing mower owner’s responsibility to make certain that owner's manual be available to the operator prior to operating:
 - 1- Reads and understands the operator’s manuals.
 - 2- Is instructed in safe and proper use.
- I Know your controls and how to stop tractor, engine, and the mower quickly in an emergency. Read this manual and the one provided with your tractor.
- I Train all new personnel and review instructions frequently with existing workers. Be certain only a properly trained and physically able person will operate the machinery. A person who has not read and understood all operating and safety instructions is not qualified to operate the machine. An untrained operator exposes himself and bystanders to possible serious injury or death. If the elderly are assisting with farm work, their physical limitations need to be recognized and accommodated.

PREPARATION



- I Never operate the tractor and mower until you have read and completely understand this manual, the Tractor Operator's Manual, and each of the safety messages found on the safety signs on the tractor and mower.
- I Personal protection equipment including hardhat, safety glasses, safety shoes, and gloves are recommended during assembly, installation, operation, adjustment, maintenance, repairing, removal, or moving the implement. Do not allow long hair, loose fitting clothing, or jewelry to be around equipment.
- I **PROLONGED EXPOSURE TO LOUD NOISE MAY CAUSE PERMANENT HEARING LOSS!** Tractors with or without mowers attached can often be noisy enough to cause permanent, partial hearing loss. We recommend that you wear hearing protection on a full-time basis if the noise in the operator's position exceeds 80 db. Noise over 80 db on a long-term basis can cause severe hearing loss. Noise over 90 db adjacent to the operator over a long-term basis may cause permanent, total hearing loss. **NOTE:** Hearing loss from loud noise (from tractors, chain saws, radios, and other such sources close to the ear) is cumulative over a lifetime without hope of natural recovery.
- I Operate the mower only with a tractor equipped with an approved Roll-Over-Protective System (ROPS). Always wear your seat belt. Serious injury or even death could result from falling off the tractor — particularly during a turnover when the operator could be pinned under the ROPS or the tractor.
- I Clear area to be cut of stones, branches or other debris that might be thrown, causing injury or damage.
- I Operate only in daylight or good artificial light.
- I Ensure mower is properly mounted, adjusted and in good operating condition.
- I Ensure that all safety shielding and safety signs are properly installed and in good condition.

STARTING AND STOPPING SAFETY



- I Check the tractor master shield over the PTO stub shaft. Make sure it is in good condition and fastened securely to the tractor. Purchase a new shield if old shield is damaged or missing.
- I All tractors that are not equipped with a "live" power takeoff (PTO) need to be equipped with an over-running PTO clutch. These are available through most farm equipment stores. **NOTE:** The addition of an over-running PTO clutch may change the length of the PTO driveline required. Pay extra attention to the instructions on the PTO driveline Installation. Be sure that the driveline system guarding is adequate.
- I Mower operating power is supplied from tractor PTO. Refer to your tractor manual for PTO engagement and disengagement instructions. Know how to stop tractor and mower quickly in case of an emergency.
- I When engaging PTO, the engine RPM should always be at idle speed. Once engaged and ready to start cutting, raise PTO speed to 540 RPM and maintain throughout cutting operation.

OPERATIONAL SAFETY



- I The use of this equipment is subject to certain hazards that cannot be protected against by the mechanical means or product design. All operators of this equipment must read and understand this entire manual, paying particular attention to safety and operating instructions, prior to using. If there is something in this manual you do not understand, ask your supervisor, or your dealer, to explain it to you.
- I Most accidents occur because of neglect or carelessness. Keep all helpers and bystanders at least several hundred feet from an operating finishing mower. Only properly trained people should operate this machine.
- I When machine is operated in populated areas where thrown objects could injure persons or property, **operation must be stopped when anyone comes within several hundred feet.**
- I The majority of the accidents involve entanglement on the driveline, injury of bystanders by the objects thrown by the rotating blades, and operators being knocked off the tractor by low hanging limbs and then being run over by the mower. Accidents are most likely to occur with machines that are loaned or rented to someone who has not read the owner's manual and is not familiar with a finishing mower.
- I The finishing mower is designed for use only on tractors with **540-RPM** power take off.
- I Install and secure all guards and shields before starting or operating. The discharge chute, bands, flaps, driveline guards and tractor, shields should be used and maintained in good working condition. They should be inspected carefully, at least daily, for missing or broken cable, chain links, shields, or guards. (Worn items must be replaced at once to reduce possibility of injury)
- I Disengage power takeoff (PTO) and place transmission in neutral before attempting to start engine.
- I Many varied objects, such as wire, cable, rope, or chains, can become entangled in the operating parts of the mower. These items could then swing outside the housing at greater velocities than the blades. Such a situation is extremely hazardous. Inspect the cutting area for such objects before mowing. Remove any like objects from the site.

OPERATIONAL SAFETY *continued...*



- I Never allow the cutting blade to contact such items. Cut material higher at first, allowing finishing mower to clear hidden objects. Never assume an area is clear.
Always Check!
- I Always stop the tractor, disengage PTO, set brake, shut off the tractor engine, remove the ignition key, lower implement to the ground and allow cutter blades to come to a complete stop before dismounting tractor. Never leave equipment unattended with the tractor running.
- I Never place hands or feet under mower with tractor engine running or before you are sure all motion has stopped. Stay clear of all moving parts.
- I Do not reach or place any part of your body under equipment until it is blocked securely.
- I Do not allow riders on the finishing mower or tractor at anytime. There is no safe place for any riders.
- I Do not operate unless all personnel, livestock, and pets are several hundred feet away to prevent injury by thrown objects. Never direct discharge chute toward anyone.
- I Never operate tractor and finishing mower under trees with low hanging limbs. Operators can be knocked off the tractor and then run over by the rotating blades.
- I The rotating parts of this machine have been designed and tested for rugged use. However, they could fail upon impact with heavy, solid objects such as steel guardrails and concrete abutment. Such impact could cause the broken objects to be thrown outward at very high velocities. To reduce the possibility of property damage, serious injury, or even death, never allow the cutting blades to contact such obstacles.
- I Stop mower and tractor immediately upon striking an obstruction. Turn engine off, remove key, inspect and repair any damage before resuming operation.
- I Stay alert for uneven terrain, holes, rocks, and roots and other hidden hazards. Keep away from drop-offs and hazards that could cause roll over. Use extreme care and maintain minimum ground speed when transporting or operating on hillsides, over rough ground and when operating close to ditches or fences. Be careful and slow down when turning sharp corners and changing direction on slopes. Do not start or stop suddenly on slopes. Avoid operation on steep slopes. In extremely uneven terrain, rear wheels weights, front tractor weight, and/or tire ballast should be used to improve stability.

OPERATIONAL SAFETY *continued...*



- I Pass finishing mower diagonally through sharp dips and avoid sharp drops to prevent “hanging up” tractor and finishing mower. Practice will improve your skills in maneuvering on rough terrain. Always cut down slopes, never across the face. Always check tractor manual for proper use on slopes.
- I When using a unit, a minimum 20% of tractor and equipment weight must be on tractor front wheels. Without this weight, tractor could tip over, causing personal injury or death. The weight may be attained with a front- end loader, front wheel weights, ballast in the tires or front tractor weights. When attaining a minimum 20% of tractor and equipment weight on the front wheels, you must not exceed the ROPS weight certification. Weigh the tractor and equipment. **Do not guess or estimate!**

TRANSPORT SAFETY



- I Comply with state and local laws governing highway safety and movement of farm machinery on public roads.
- I The use of flashing amber lights is acceptable in most localities. However, some localities prohibit their use. Local laws should be checked for all lighting and marking requirements.
- I At all times, when driving the tractor and equipment on the road or highway under 20 mph (32 kph) use flashing amber warning lights and a slow moving vehicle (SMV) identification emblem. Do not exceed 20 mph (32 kph). Reduce speed on rough roads and surfaces.
- I Plan your route to avoid heavy traffic.
- I Always install transport locks, pins or brackets before transporting.
- I Do not drink and drive.
- I Be a safe and courteous driver. Always yield to oncoming traffic in all situations, including narrow bridges, intersections, etc. Watch for traffic when operating near or crossing roadways.
- I Turn curves or go up or down hills only at a low speed and at a gradual steering angle. Make certain that a least 20% of the tractor’s weight is on the front wheels to maintain safe steering. Slow down on rough or uneven surface. Always check tractor manual for proper use on slopes.
- I Use extreme care and maintain minimum ground and when operating close to ditches or fences. Be careful when turning sharp corners.
- I Never allow riders on either tractor or mower.

ATTACHING TO TRACTOR



WARNING

Never stand between tractor and finishing mower while backing up tractor to the hitch.

STEP 1 Attach to tractor's category 1 three point hitch as described in the Tractor's Operator's Manual.

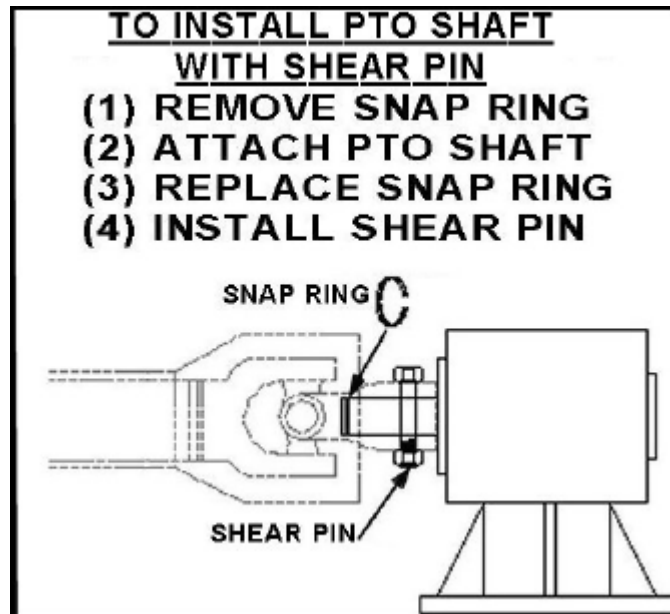

WARNING



Failure to install retaining clip on gearbox input shaft would allow driveline to swing freely if bolt is sheared causing possible injury or death.

STEP 2

Determine if the PTO shaft needs to be shortened.

NOTE:

Due to the many variations in the tractor hitch points and distances between equipment gearbox input shaft and tractor PTO output shafts, some combinations may require PTO shafts to be shortened as described by the following steps.

STEP 3

Raise and lower finishing mower in order to locate the shortest distance between equipment gearbox input shaft and tractor PTO output shaft. With the finishing mower in the shortest distance position shut down the tractor and **SECURELY BLOCK FINISHING MOWER IN POSITION.**

STEP 4

Pull apart PTO shaft and attach outer section to tractor PTO output shaft. **NOTE:** Be sure to pull on PTO shaft section to ensure yoke has locked into place.

ATTACHING TO TRACTOR *continued....*

STEP 5

Place and hold inner PTO shaft section next to outer section and check if PTO shaft is too long. Each section should end approximately 3 inches short of reaching u-joint shield on the opposite section. If the shaft is too long measure 3 inches back from each u-joint shield and mark the other shaft section. Be sure to do this for both PTO shaft halves. NOTE: Do not cut PTO shaft sections at this time.

STEP 6

Raise finishing mower and remove blocking. Raise and lower finishing mower in order to locate the longest distance between equipment input shaft and the tractor PTO output shaft. With the finishing mower in the longest distance position shut down the tractor and **SECURELY BLOCK THE FINISHING MOWER IN POSITION.**

STEP 7

As in step 5 hold PTO shaft sections together and check for a minimum of 6 inches of overlap. If PTO shaft has been marked for cutting the overlap is the distance measured between the two marks. If the PTO shaft has less than a 6 inch overlap, **DO NOT USE.** Contact your authorized King Kutter Dealer.

NOTE

If the PTO shaft length is too long go to **SIZING PTO SHAFT (pg. 18)**

STEP 8

Apply any multi-purpose grease to the outside of the male (inner) PTO shaft section. Assemble PTO shaft and install on finishing mower and tractor.

WARNING - Failure to install retaining clip on gearbox input shaft would allow driveline to swing freely if bolt is sheared causing possible injury or death.

STEP 9

Pull on tractor side of PTO shaft yoke to be sure it has locked in place. Make certain PTO shaft shielding is in place and good working condition.

STEP 10

The PTO shaft shield is a non-rotating design and must be secured prior to equipment use. Using the chain on each yoke shield attach to a fixed object on the tractor and equipment ends that will not allow the PTO shaft shield to rotate during operation.

SIZING PTO SHAFT

STEP 1

Cutting the PTO shaft to length. NOTE: Be sure to cut equal lengths of each PTO shaft section. Clamp end of PTO shaft in a vice and cut off shield where marked. (Figure 1-A & 1-B)



Figure 1-A

STEP 2

Using cut section of the shield as a guide cut shaft off the same amount. (Figure 2)



Figure 1-B

STEP 3

Repeat steps 1 and 2 for other PTO shaft section.

STEP 4

Use a file to deburr PTO shafts. Clean up all chips, burrs and filings from both ends of the PTO shaft.

Note: If you shear the bolt that attaches the PTO shaft to the gearbox replace with a grade 2 bolt only. Replacement with another grade of bolt will void your warranty and may cause terminal damage to the PTO shaft, gearbox, or tractor.



Figure 2

OPERATING INSTRUCTIONS

This mower was designed to CUT LAWN GRASS ONLY. Use of your finishing mower to cut any material other than lawn grass may damage the mower and void your warranty.

CUTTING HEIGHT ADJUSTMENT

To prevent blades from striking the ground your finishing mower should be set to the highest position that will give desired grass height. By setting your mower up this way you reduce blade wear and stress on the mower. Mowing at regular intervals will yield far better results than periodic mowing. (*i.e.* weekly vs. by-weekly mowing.)

STEP 1

Raise finishing mower off the ground with the tractor and **SECURELY BLOCK IN POSITION**.

STEP 2

Remove pin from top of wheel fork assembly. Lower wheel fork assembly from tail wheel arm.

STEP 3

Arrange spacers until desired cutting height is achieved. Cutting heights range from approximately 2.0-6.0 inches in height.

STEP 4

Reinstall wheel fork assembly into tail wheel arm and install keeper pin.

STEP 5

Repeat adjustment process on remaining wheel fork assemblies.
NOTE: Make sure all are adjusted to the same height for an even cut.

FINISHING MOWER OPERATION

STEP 1

Before each use perform the maintenance described in maintenance section (pg.# 21)

STEP2

Read, understand, and follow the information on safety training, preparation, starting and stopping safety, operational safety, transport safety warning sections of this manual (pages 11 thru 16)

STEP 3

With tractor running, lower finishing mower to ground so that the swivel links are parallel to the ground. This allows the free-floating hitch system to follow the contour of the ground, thus mowing evenly on uneven terrain.

STEP 4

With the tractor at idle RPM, engage PTO and slowly advance throttle to 540 PTO RPM. NOTE: Finishing mower designed to run at 540 PTO RPM only.

STEP 5

Select a low gear for the tractor and begin to mow. Tractor ground speed is to be controlled by gear selection only and not engine speed. Tractor ground speed should allow finishing mower to maintain 540 PTO RPM and thus maximum blade tip speed.

NOTE: Do not allow the tractor engine or finishing mower to bog down or stall. This causes undue wear and tear on the mower and tractor. If this continues to happen reduce ground speed and raise cutting height of finishing mower. Never attempt to clean out a plugged discharge chute until the tractor has been shut down and the mower blades have completely stopped.

STEP 6

After each use clean all debris from the top and bottom of the finishing mower. Replace any missing or illegible safety decals. Inspect for any damaged or worn parts and replace before next use. Store finishing mower in a dry environment.

MAINTENANCE

- 1). Periodically check and maintain proper gear oil level.
- 2). Every 8 hours, grease spindles (3), roller axle (1), wheel forks (4), wheel axles (4), PTO shaft universal joints (2), and PTO telescoping surface.

NOTE: Use only a grade Type II tube grease.

- 3). Before each use check to make sure all safety features are installed and working properly.
- 4). Keep blades sharp and balanced at all times. When replacing blades, replace all 3 blades and blade bolts at the same time.

NOTE: Blade bolts are left hand thread!

- 5). Periodically check all nuts, bolts, and belt to insure they are tight and secure.

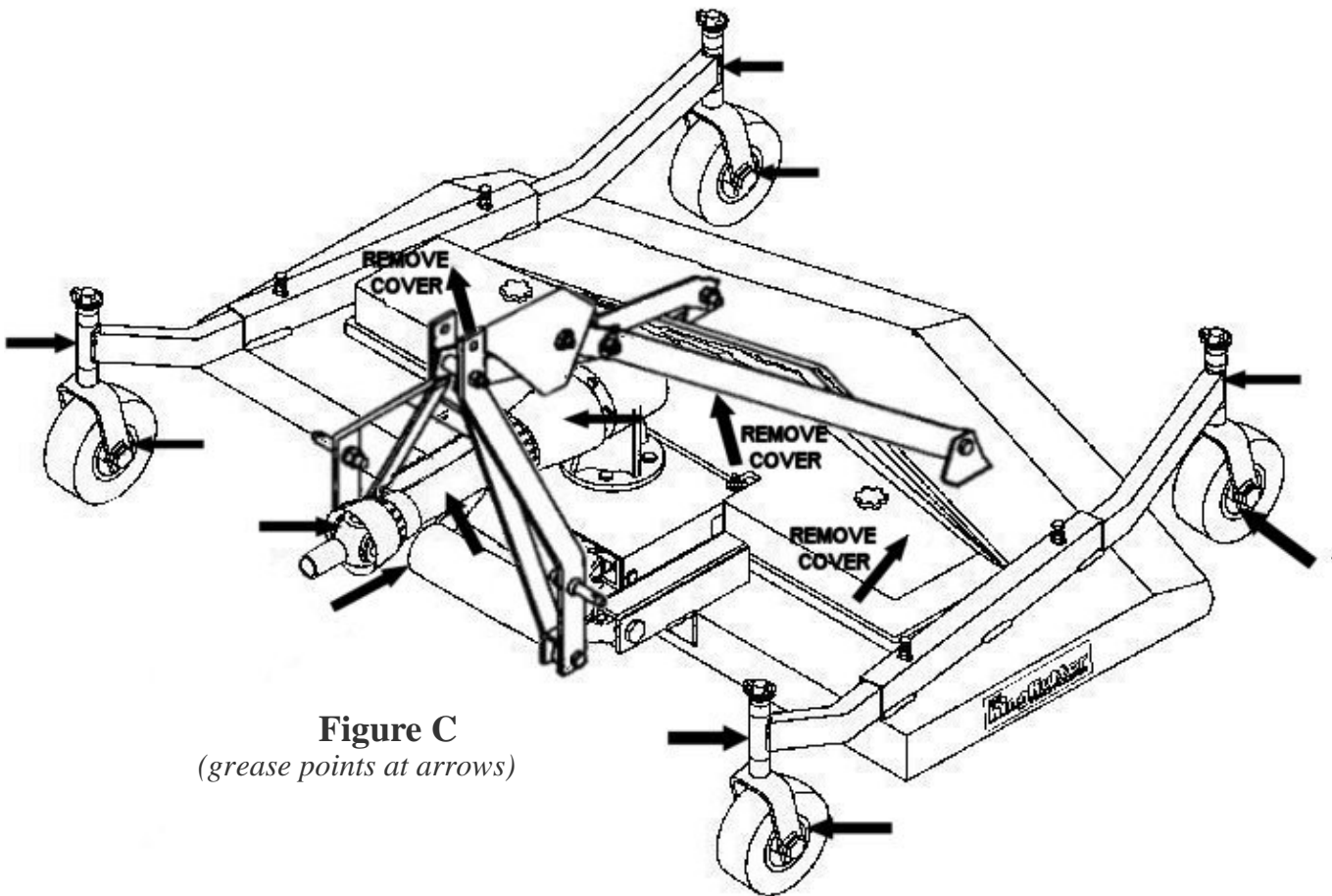

Figure C
(grease points at arrows)

5-6-7 FT. FINISHING MOWER

TO REPLACE BELT:

- STEP 1** Remove top cover.
- STEP 2** Release adjustment spring.
- STEP 3** Loosen nut on adjustment pulley to allow for movement. (See Figure "D")
- STEP 4** Loosen nut on right side of "L" bracket. (See Figure "D")
- STEP 5** Loosen belt by moving adjustment pulley in opposite direction you would to tighten belt.
- STEP 6** Remove nuts (2) from hinged gearbox plate from finishing mower deck. (See Figure E)
- STEP 7** Loosen nuts (2) from hinged bolt gearbox plate.
- STEP 8** Raise gearbox assembly and slip out belt.
- STEP 9** See Figure D for belt placement on pulleys.
- STEP 10** Do step 5 thru 7 under Section: "TO ADJUST BELT" to tighten.

TO ADJUST BELT:

- STEP 1** Remove top cover.
- STEP 2** Release adjustment spring.
- STEP 3** Loosen nut on adjustment pulley to allow for movement. (See Figure D)
- STEP 4** Loosen nut on right side of "L" bracket. (See Figure D)
- STEP 5** Turn nut on left side of "L" bracket in counter clockwise direction until belt is tight.
- STEP 6** Re-tighten nut on right side of "L" bracket and nut on adjustment pulley.
- STEP 7** Re-hook adjustment spring. (See Figure "D")

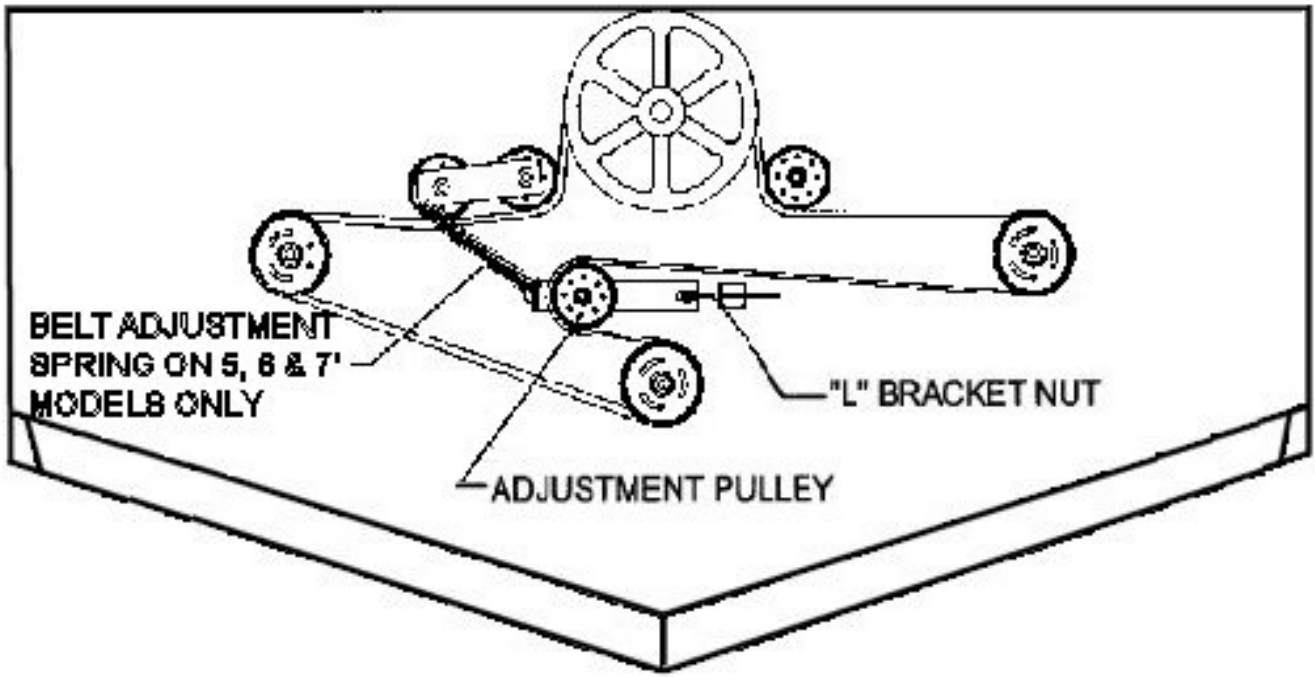

Figure D

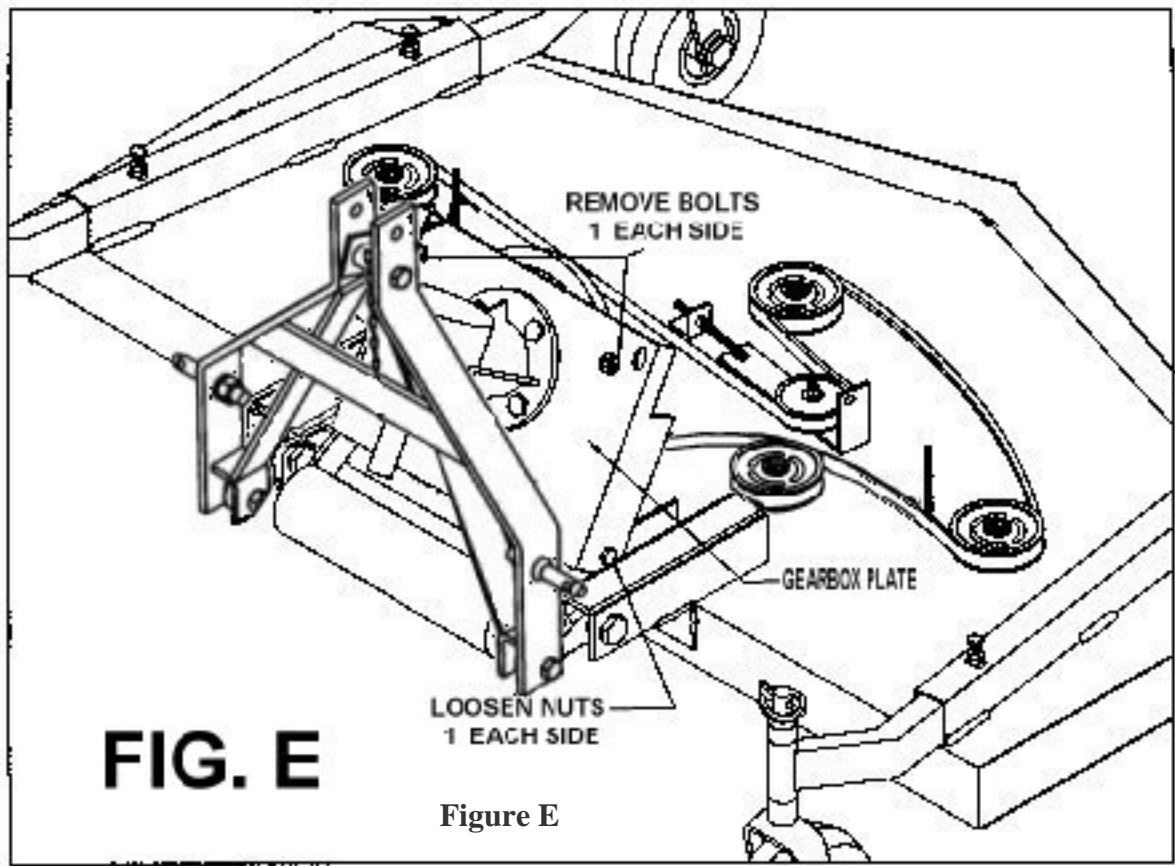

Figure E

4 FT. FINISHING MOWER ONLY

TO REPLACE BELT:

- STEP 1** Remove top cover.
- STEP 2** Loosen nut on adjustment pulley to allow for movement. (See Fig. "D")
- STEP 3** Loosen nut on right side of L Bracket. (See Fig. "D")
- STEP 4** Loosen belt by moving adjustment pulley in opposite direction you would to tighten belt.
- STEP 5** Remove bolts (2) from hinge bolt gearbox plate from finishing mower deck. (See Fig. E).
- STEP 6** Loosen nuts (2) from hinge bolt gearbox plate.
- STEP 7** Raise gearbox assembly and pull out belt.
- STEP 8** See (Fig. D) for belt placement on pulleys.
- STEP 9** Do step 4 & 5 under section: "TO ADJUST BELT" to tighten.

TO ADJUST BELT:

- STEP 1** Remove top cover.
- STEP 2** Loosen nut on adjustment pulley to allow for movement. (See Fig. "D")
- STEP 3** Loosen nut on right side of L Bracket. (See Fig. "D")
- STEP 4** Turn nut on left side of L Bracket in counter clockwise direction until belt is tight.
- STEP 5** Retighten nut on right side of L Bracket and nut on adjustment pulley.

4 FT. FINISHING MOWER ONLY

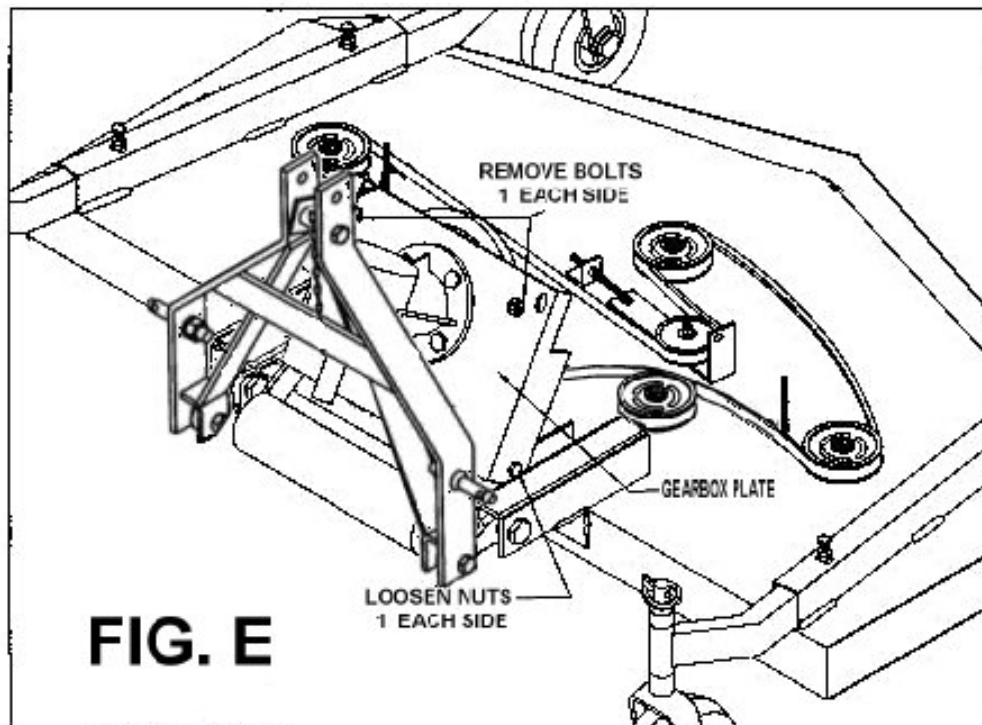
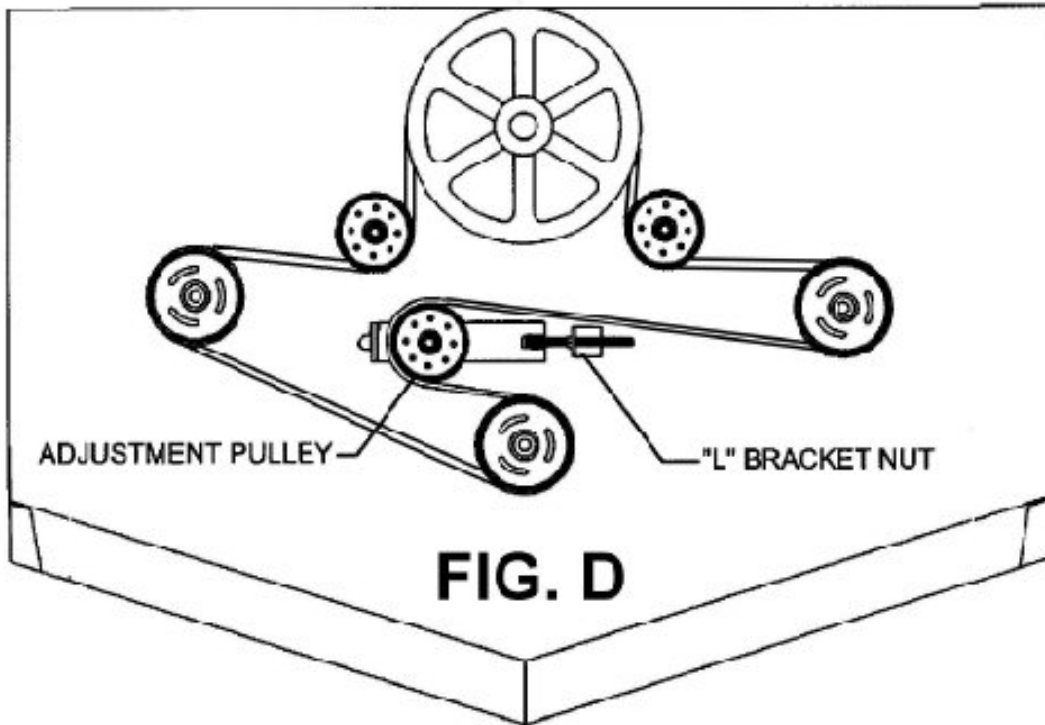

MAINTENANCE SAFETY



- I Good maintenance is your responsibility. Poor maintenance is an invitation to trouble.
 - I Follow good shop practices.
 - I Keep service area clean and dry
 - I Be sure electrical outlets and tools are properly grounded
 - I Use adequate light for the job at hand.

- I Make sure there is plenty ventilation. Never operate the engine of the towing vehicle in a closed building. The exhaust fumes may cause asphyxiation.
- I Before working on this machine, disengage the PTO, shut off the engine, set the brakes, and remove the ignition keys.
- I Be certain all moving parts on attachments have come to a complete stop before attempting to perform maintenance.
- I Never work under equipment unless it is blocked securely.
- I Always use personal protection devices such as eye, hand and hearing protectors, when performing any service or maintenance.
- I Frequently check mower blades. They should be sharp, free of nicks and cracks and securely fastened. **NOTE: Blade bolts are left hand thread!**
- I Periodically tighten all bolts, nuts, and screws and check that all cotter pins are properly installed to ensure unit is in safe condition.
- I When completing a maintenance or service function, make sure all safety shields and devices are installed before placing unit in service.
- I After servicing, be sure all tools, parts and service equipment are removed from mower.
- I Do not allow debris, grease or oil to build up on any deck or platform.
- I Where replacement parts are necessary for periodic maintenance and servicing, genuine factory replacement parts must be used to restore your equipment to original specifications.
- I The manufacturer will not be responsible for injuries or damages caused by use of unapproved parts and/or accessories.
- I A fire extinguisher and the first aid kit should be kept readily accessible while performing maintenance on this equipment.

STORAGE SAFETY



- I Following operation, or when unhooking the mower, stop the tractor, set the brakes, disengage the PTO, shut off the engine and remove the ignition keys.
- I Store the unit in an area away from human activity.
- I Do not park equipment where it can be exposed to direct contact to livestock for long periods of time. Damage and livestock injury could result.
- I Make sure all parked machines are on a hard, level surface and engage all safety devices.

SAFETY SIGN LOCATIONS

The types of safety signs and locations on the equipment are shown in the illustration below. Good safety requires that you familiarize yourself with the various safety signs, the type of warning and the area, or particular function related to that area, that requires your **SAFTY AWARENESS**

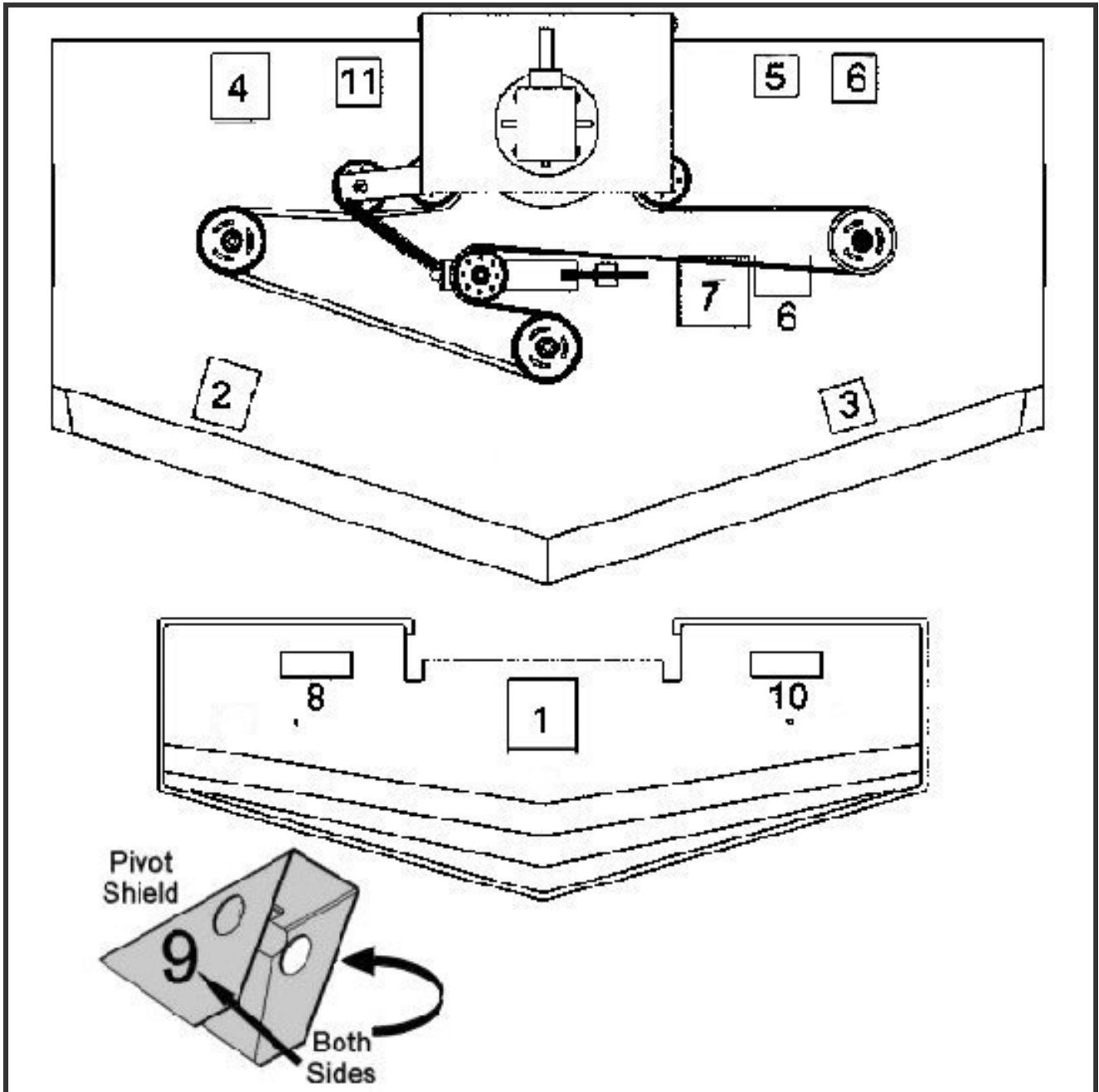

REMEMBER: If safety signs have been damaged, removed, become illegible or parts have been replaced without signs, new safety signs must be applied. New safety signs are available from your authorized dealer, distributor or factory.

WARNING

To prevent serious injury or death:

Si no lee inglés, pida ayuda a alguien que sí lo lee para que le traduzca las medidas de seguridad.

- Read and understand Operator's Manual before using. Review annually.
- Do not permit riders on the tractor or mower, including children.
- Do not allow children to operate mower.
- Operate only with guards installed and in good working condition.
- Keep away from moving parts.
- Operate only with tractor equipped with ROPS and seatbelts.
- Before mowing, clear debris from mowing area.
- Do not operate in the raised position.
- Stop engine, lower mower, set brake and wait for all moving parts to stop before dismounting.
- Support mower securely before working beneath unit.
- Transport with clean reflectors, SMV and working lights as required by federal, state, and local laws.
- Keep yourself, others, and clothing away from the rotating PTO.
- Keep others away from area to be mowed to avoid injury from flying objects.
- Do not stand between tractor and mower.
- Be careful on uneven terrain. Decrease speed when turning.
- Do not exceed a safe transport speed.

! DANGER



ROTATING BLADES-KEEP AWAY

To prevent serious injury or death when the engine is running and the blades are rotating:

- Never allow riders, especially children, on tractor or mower.
- Do not operate with bystanders in mowing area.
- Do not operate with deflectors/guards removed.
- Do not place hands or feet under deck.
- Do not stand on or near implement at any time.
- Do not stand between tractor and implements.
- Operate only with tractor equipped ROPS and seatbelts.

2

! DANGER



THROWN OBJECT HAZARD

To prevent serious injury or death:

- Do not operate unless all guards are installed and in good condition.
- Stop blade rotation if bystanders come within several hundred feet.

3

DANGER



ROTATING DRIVELINE HAZARD KEEP AWAY

To prevent serious injury or death from rotating driveline:

- Keep all guards in place when operating.
- Operate only at 540 RPM
- Keep hands, feet, clothing and hair away from moving parts.
- Do not operate without driveline securely attached at both ends.
- Do not operate without driveline shields that turn freely on driveline.

4

WARNING



MOVING PART HAZARD

To prevent serious injury or death from moving parts:

- Close and secure guards and shields before starting.
- Keep hand, feet, hair and clothing away from moving parts.
- Disconnect and lockout power source before adjusting or servicing.
- Do not stand or climb on machine when operating.

5

⚠ WARNING



TO PREVENT SERIOUS INJURY OR DEATH

- Keep hands and body out of hitch area when attaching mower to tractor.
- Keep body clear of crush point between tractor and mower.

6

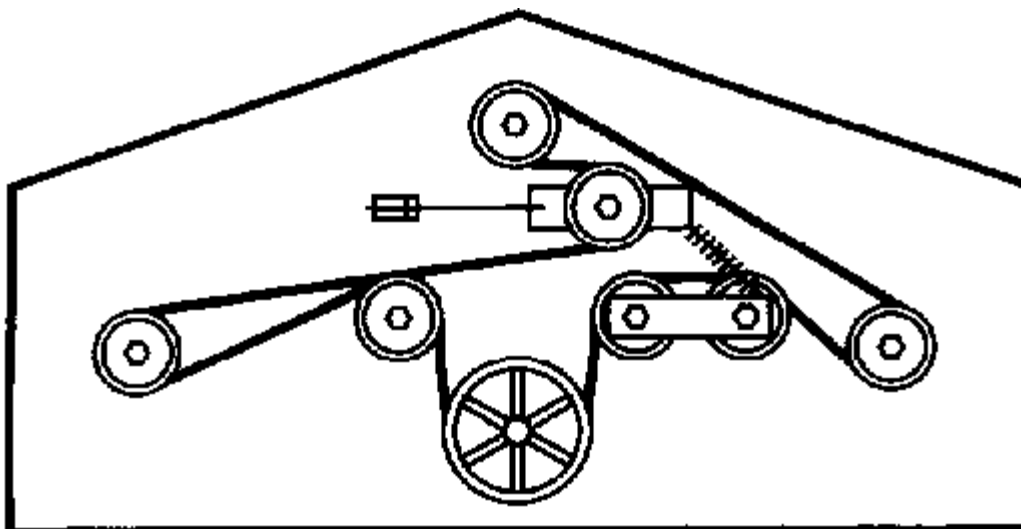

7

**FOR LAWN
GRASS ONLY**

8



9

**NO GREASE
IN FITTINGS
WHEN SHIPPED.**

10

**Operators Manuals are
available from
your dealer, or**

**King Kutter, INC.
P.O. Box 1200
Winfield, AL 35594
(205) 487-3202
www.kingkutter.com**

11



**MODEL NO.
DESCRIPTION
SN# XXXXXXXXXX**

12

REAR DISCHARGE FLEX HITCH FINISHING MOWER

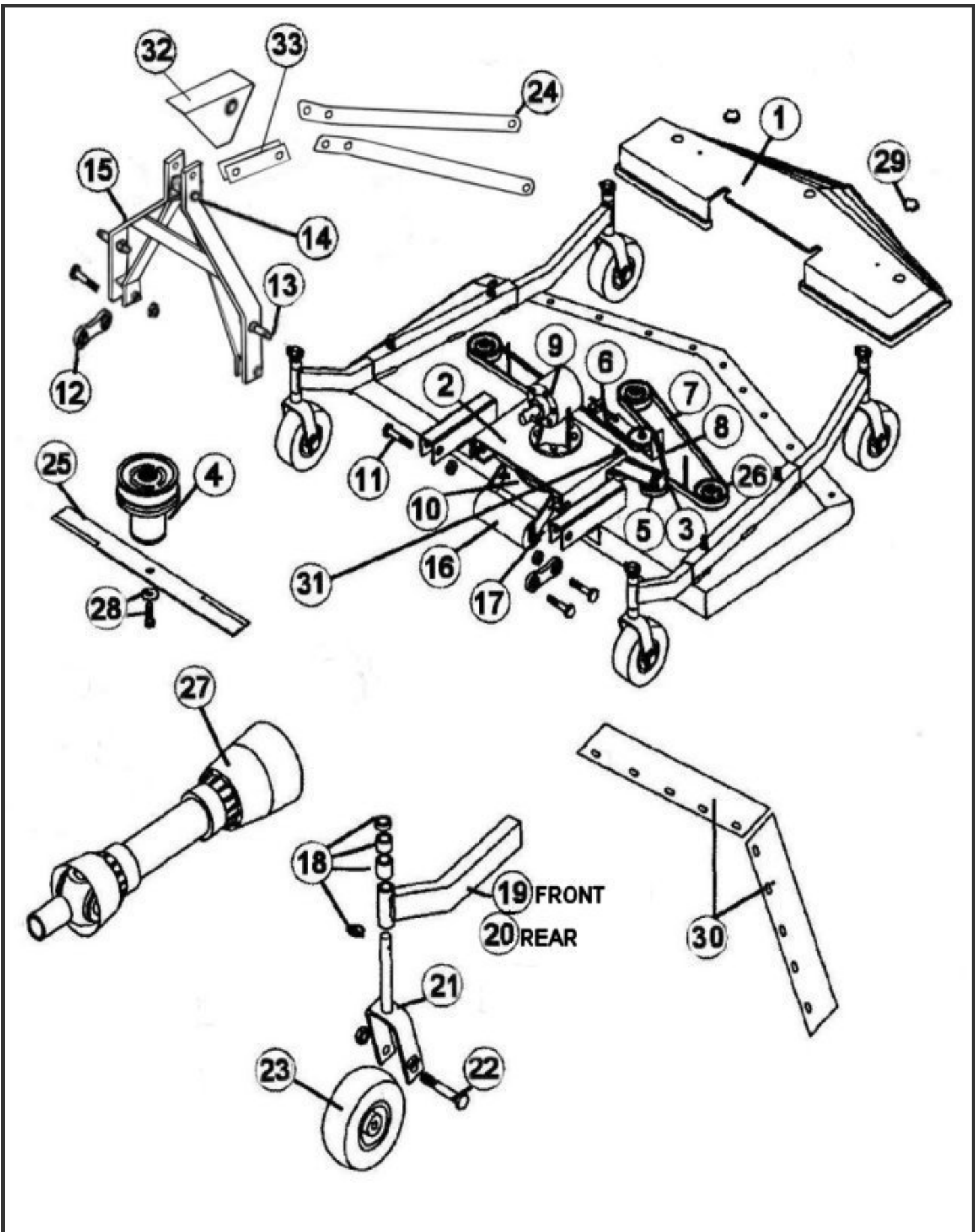

Ref. No.	Part Name	4'	5'	6'	7' STAINLESS
1	Top Cover	124684	124685	124686	124687
2	Gear Box Plate	403029	403025	403025	403025
3	Idler Pulley Bracket	-	312647	312647	-
3	Double-Idler Pulley Bracket	-	-	312647	312641
4	Spindle Unit - Single	502303	502303	502303	-
4	Spindle Unit - Double	-	-	502304	502304
5	Idler Pulley - Single	164090	164090	164090	-
5	Idler Pulley- Double	-	-	164091	164091
6	Belt Adjustment Assembly	403682	403688	403688	403688
7	V- Belt*	167108 ¹	167133 ²	167148 ³	167162 ⁴
7	V - Belt Double	-	-	167149	167163
8	Spring	-	502027	502027	502027
9	Gearbox	184000	184000	184000	184005
10	Main Pulley - Single	165114	165114	165112	165112
10	Main Pulley - Double	-	-	165113	165113
11	Swivel Link Bolt Pkg. 3/4" x 4" /w nut	502011	502011	502011	502011
12	Swivel Link Set	502010	502010	502010	502010
13	Cat. 1 Lift Pins (2/pk)	500001	500001	500001	500001
14	Lift Arm Spacer /w Bolt & Nut	501095	501095	501095	501095
15	Lift Arm Assembly	403664	403664	403664	403664
16	Center Roller /w Axle	502110	502110	502110	502110
17	Roller Axle	403670	403670	403670	403670
18	Height Adjuster Set	502120	502120	502120	502120
19	Front Tail Wheel Arm	403410	403410	403410	403410
20	Rear Tail Wheel Arm	403700	403415	403415	403415
21	Wheel Fork	403023	403023	403023	403023
22	Axle Bolt 3/4" x 5" /w Nut	502125	502125	502125	502125
23	Tire & Rim /w Axle & Nut	502015	502020	502020	502020
24	Lift Arm Brace Kit (1-Arm, 1-Bolt, 1-Spacer, 1-Flat Washer, 1- Lock Nut)	502040	502045	502050	502050
25	Blade Set /w Bolts	502316	502320	502324	502328
26	Spindle Pulley - Single	502313	502313	502313	-
26	Spindle Pulley - Double	-	-	502314	502314
27	22" PTO Shaft	147022	147022	147022	147022
28	LH Blade Bolt Set /w Washer	502310	502310	502310	502310
29	Plastic Knob	502287	502287	502287	502287
30	Belt Guards (1-LH, 1-RH)	502400	502401	502402	502403
31	Gearbox Plate Bolt Pkg.	-	502197	502197	502197
32	Pivot Shield Kit	501029	501029	501029	501029
33	Pivot Bar	401031	401031	401031	401031

*¹B-108 ²B-133 ³B-148 ⁴B-162 *167112

40 HP GEARBOX

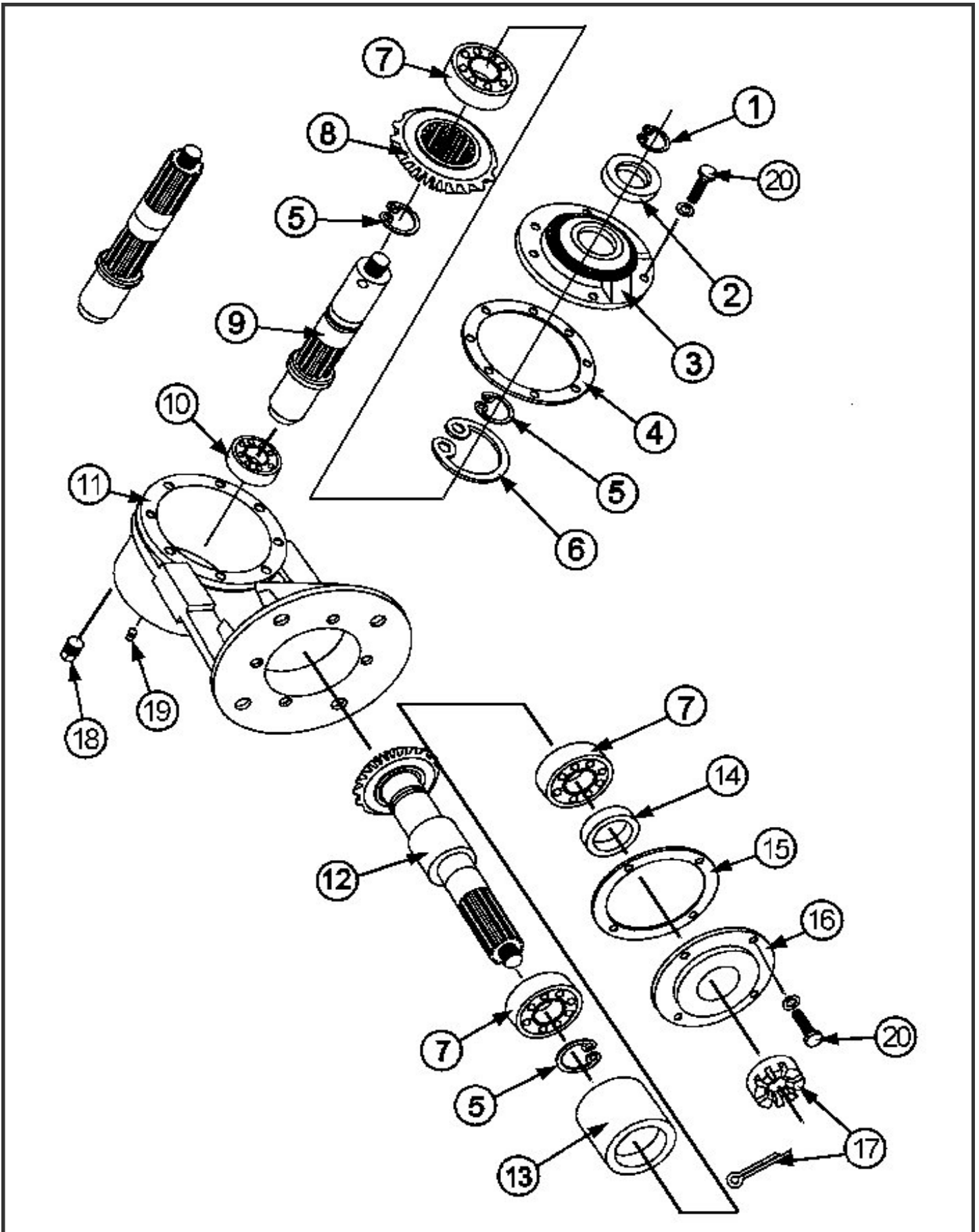

22" PTO 147022

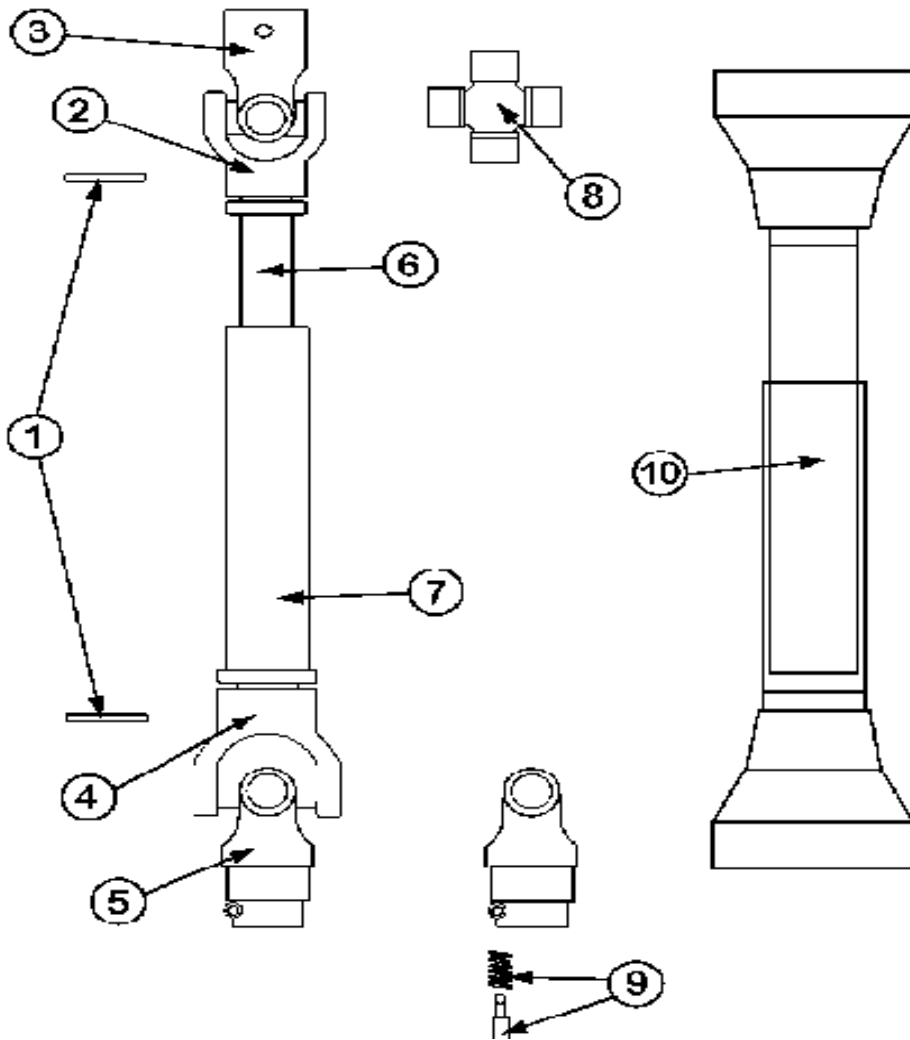

Ref. No.	Part Name	147022
1	Roll Pin Kit	500131
2	Male Tube End Yoke	151045
3	Implement End Yoke	151040
4	Female Tube End Yoke	151050
5	Tractor End Yoke	151035
6	Inner Tube 14 Series	151090
7	Outer Tube 14 Series	151091
8	Cross Kit # 4	170015
9	Quick Disconnect Pin	170110
10	Safety Shield BYPY	124310
10	Safety Shield Eurocardan	124311

Blade Spindle Unit

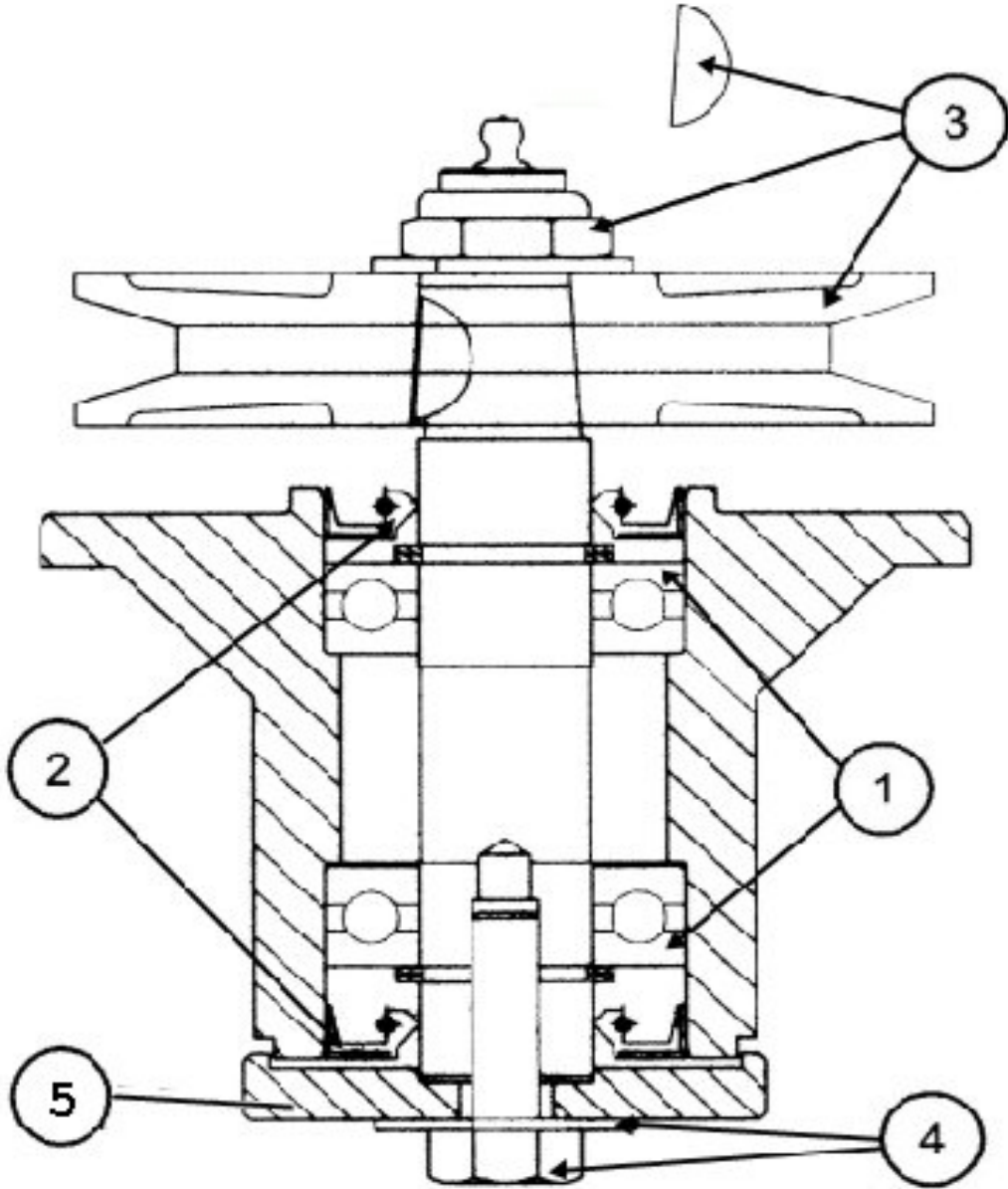

Ref. No.	Part Name	502303	502304
1 & 2	Bearing Kit - (2) Ball Bearings (6205), (2) Seals (TCM25x52x7TC), (4) Snap Rings	555009	555009
3	Spindle Pulley /w Nut & Key	502313	502314
4	Blade Bolt Set (3) /w Washer	502310	502310
5	Spindle Cap	191302	191302

PTO SHAFTS COVER REMOVAL

BONDIOLI- (BYPY)

- 1). There are 3 white tabs around the cover as shown in **(A in FIG. 1)**. Take a screwdriver and press against the tabs one at a time with downward angular pressure toward the end of shaft marked **(B in FIG. 2)**. As you are pressing tab grasp cover at point marked **(B in FIG. 2)** and apply pressure against cover in the direction of arrow, do this for each tab. (Sometimes the other tabs may relock, if they do you must repeat unlock procedure.) You will feel it click when the tab releases, after all 3 tabs are released you can slide the cover down the shaft in direction of **(C in FIG. 2)**.
- 2). To put cover back into place slide cover back toward end until all the tabs relock. (You may have to tap lightly with screwdriver or hammer handle).

NOTE: Cover may be longer on some models but, they will come off the same as above.

EUROCARDAN SERIES 4

- 1) First you must locate the black tab **(D in FIG. 3)** put flat screwdriver in slot in end of tab and turn until the flat side is pointing towards center of shaft. Once you do this take the thin flat screwdriver and put into slot labeled **(E in FIG. 3)** pry tab all the way out as shown in **(FIG. 3)**
- 2). There are 3 white tabs around the cover as shown in **(G in FIG. 4)**. You must line up cover slots and tabs **(as shown in FIG. 4, F & G)** Take a screwdriver and press against the tabs one at a time with downward angular pressure toward the end of shaft. As you are pressing tab grasp cover and apply pressure against cover in the direction of arrow, **(H in FIG-3)** do this for each tab. (Sometimes the other tabs may relock, if they do you must repeat unlock procedure.) You will feel it click when the tab releases, after all 3 tabs are released you can slide the cover down the shaft in PTO SHAFTS COVER REMOVAL direction of **(H in FIG. 3)**.
- 3) To put cover back into place slide cover back toward end (be sure tabs and slots line up) until all the tabs relock. (You may have to tap lightly with screwdriver or hammer handle). Once they have relocked replace black tab that was removed with flat side toward shaft center then turn flat side up to lock in place.

LA MAGDALENA

- 1) There are 3 black tabs around the cover **(K in FIG. 5)**. Take a screwdriver and press against the tabs one at a time with downward angular pressure toward the end of shaft marked **(J in FIG. 5)**. As you are pressing tab grasp cover at point marked **(J in FIG. 5)** and apply pressure against cover in the direction of arrow, do this for each tab.
- 2) To replace slide cover back toward end and line up black tabs with the holes and lock in place.

BONDIOLI COVER REMOVAL

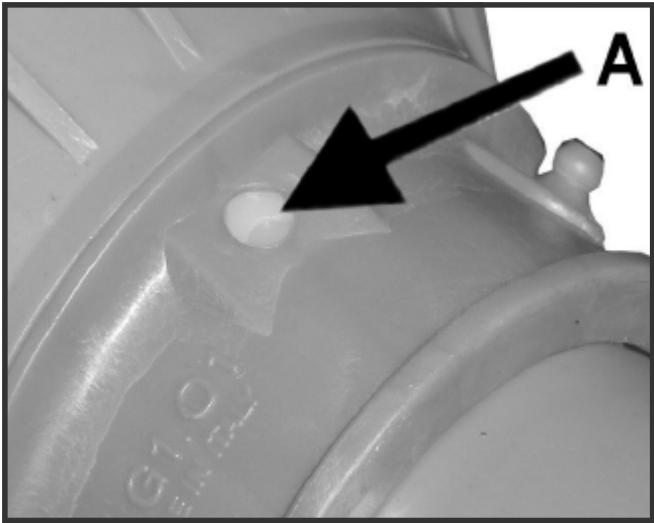

FIGURE- 1
EUROCARDAN SERIES 4 COVER REMOVAL

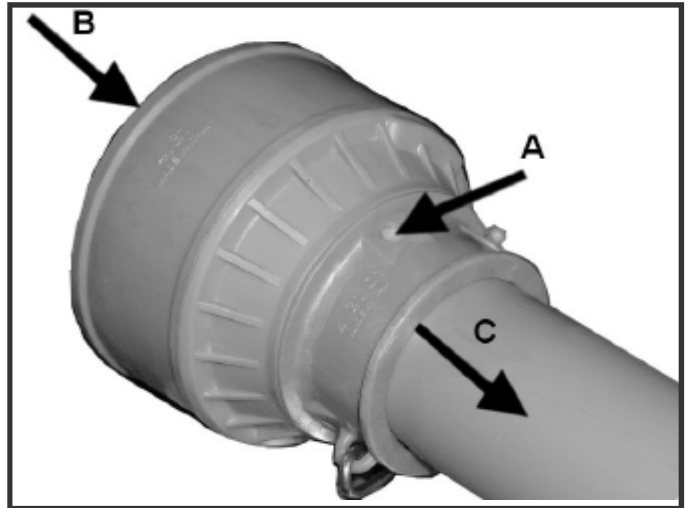

FIGURE- 2

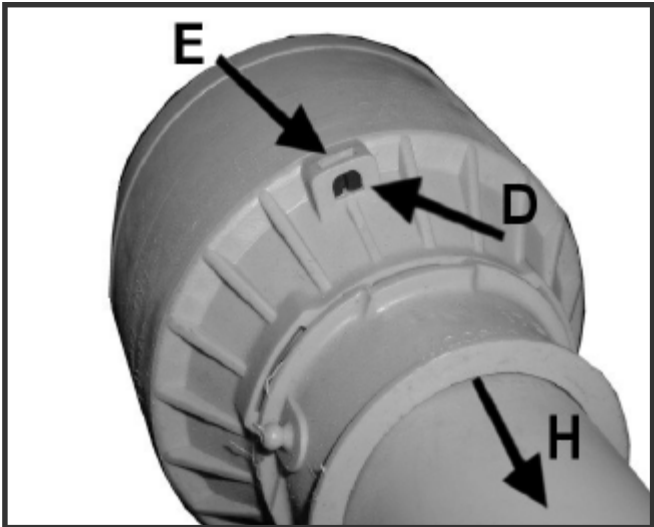

FIGURE- 3

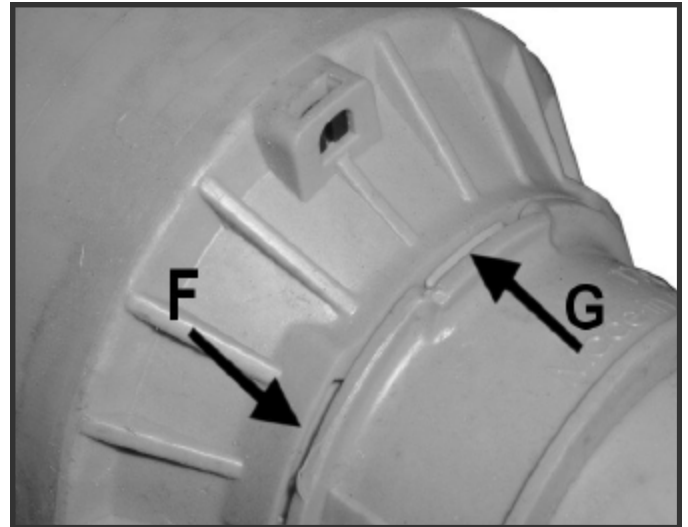
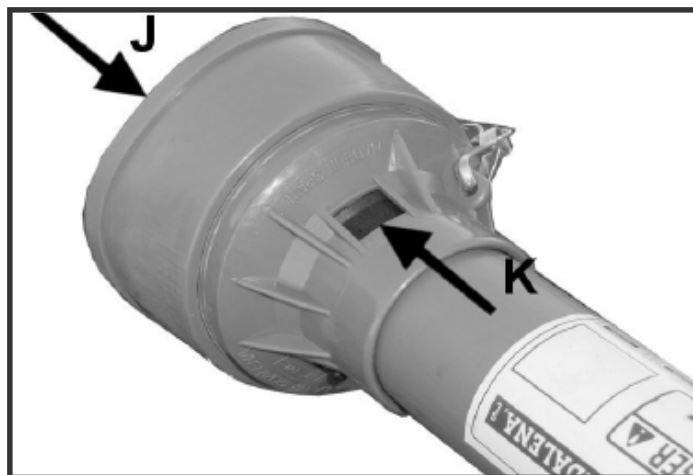

FIGURE- 4

LA MAGDALENA COVER REMOVAL

FIGURE- 5



PTO SHAFTS COVER REMOVAL

EUROCARDAN SERIES 5

- 1). There are 2 black tabs around the cover as shown in **(B in FIG. 1)**. Take a flat screwdriver and pry under the tabs one at a time at point **(B in FIG. 2)** lifting tab over on top of **(e-shaped lock)**. After both tabs are released you can slide the locking ring down the shaft in direction of **(C in FIG. 3)**. Then you will see a metal e-ring **(E in FIG. 4)** at point **(D in FIG. 4)** you must pry under ring and remove it, (it will just slide down shaft unless you take PTO apart) then apply pressure against cover **(A in FIG. 1)** in the direction of arrow and slide cover down shaft.
- 2). To put cover back into place slide cover back toward end, making sure cover and locking mechanism **(F in FIG. 4)** line up. Replace metal e-ring, slide the locking ring back into place, be sure the tabs lock securely over locks.

NOTE: Cover may be longer on some models but, they will come off the same as above.

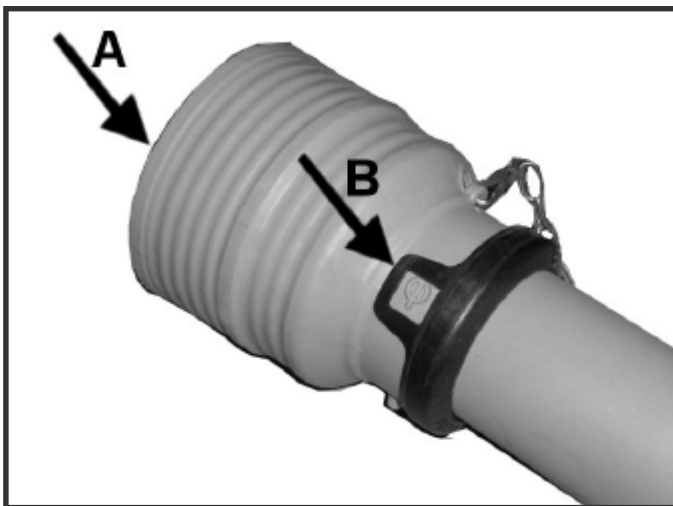

FIGURE- 1

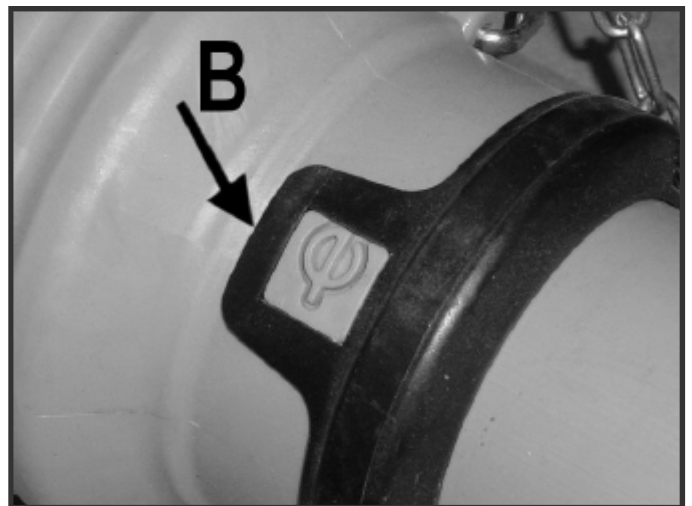

FIGURE- 2



FIGURE- 3

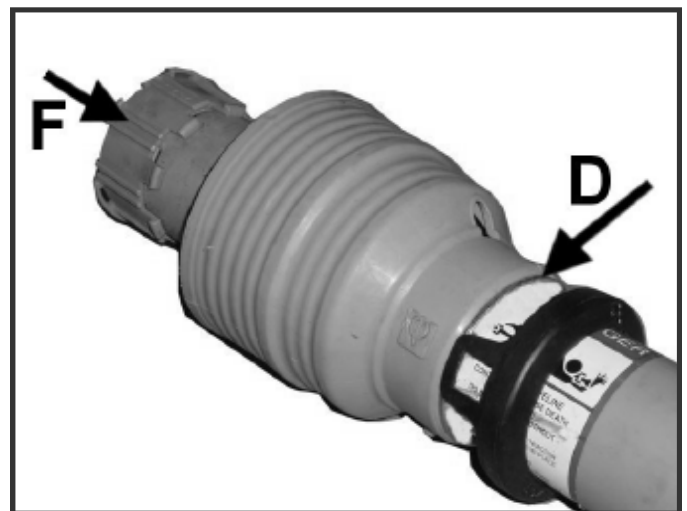

FIGURE- 4

PTO SHAFTS COVER REMOVAL

PTO SHAFTS COVER REMOVAL

RPM

- 1). Separate the two halves of the drive line.
- 2). Locate the bearing clip at either end of the driveline. Insert a flathead screw driver into the groove indicated in (Figure 11), below. While pressing inward on the arm of the bearing clip, rotate the bearing clip in the counter clock wise direction in (Figure 12).

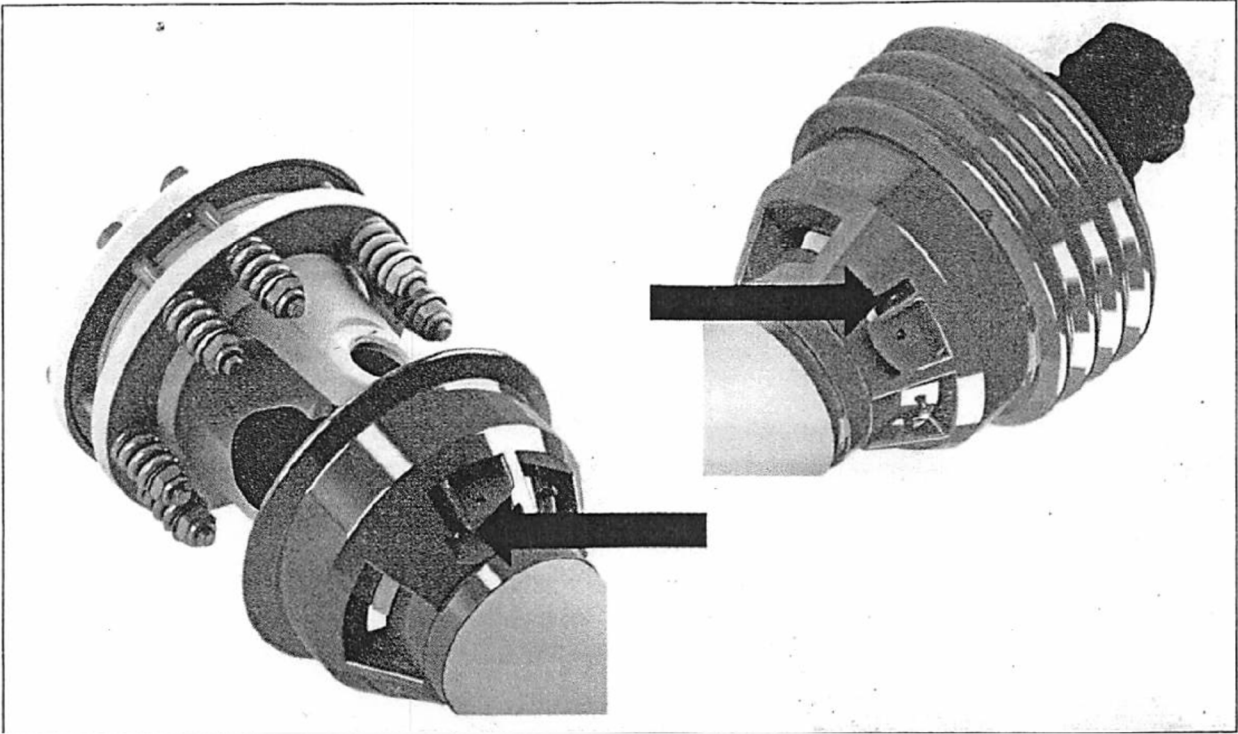

Figure 11 (Step 2)

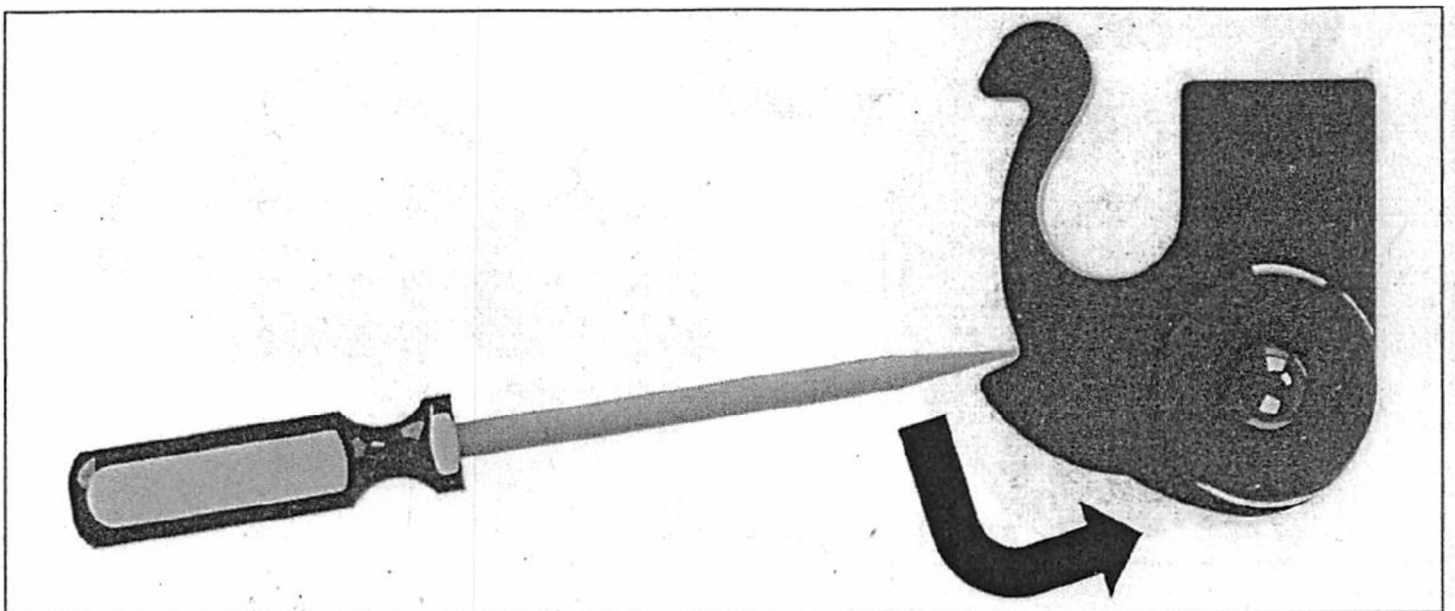

Figure 12 (Step 2)

PTO SHAFTS COVER REMOVAL

RPM Continued

3). With the bearing clips disengaged, locate the bearing tabs at either ends of the drive line (Figure 13). Insert a flathead screwdriver in the groove indicated in (Figure 14), below. Rotate the bearing tab approximately an eighth of a turn in the counter clockwise direction.

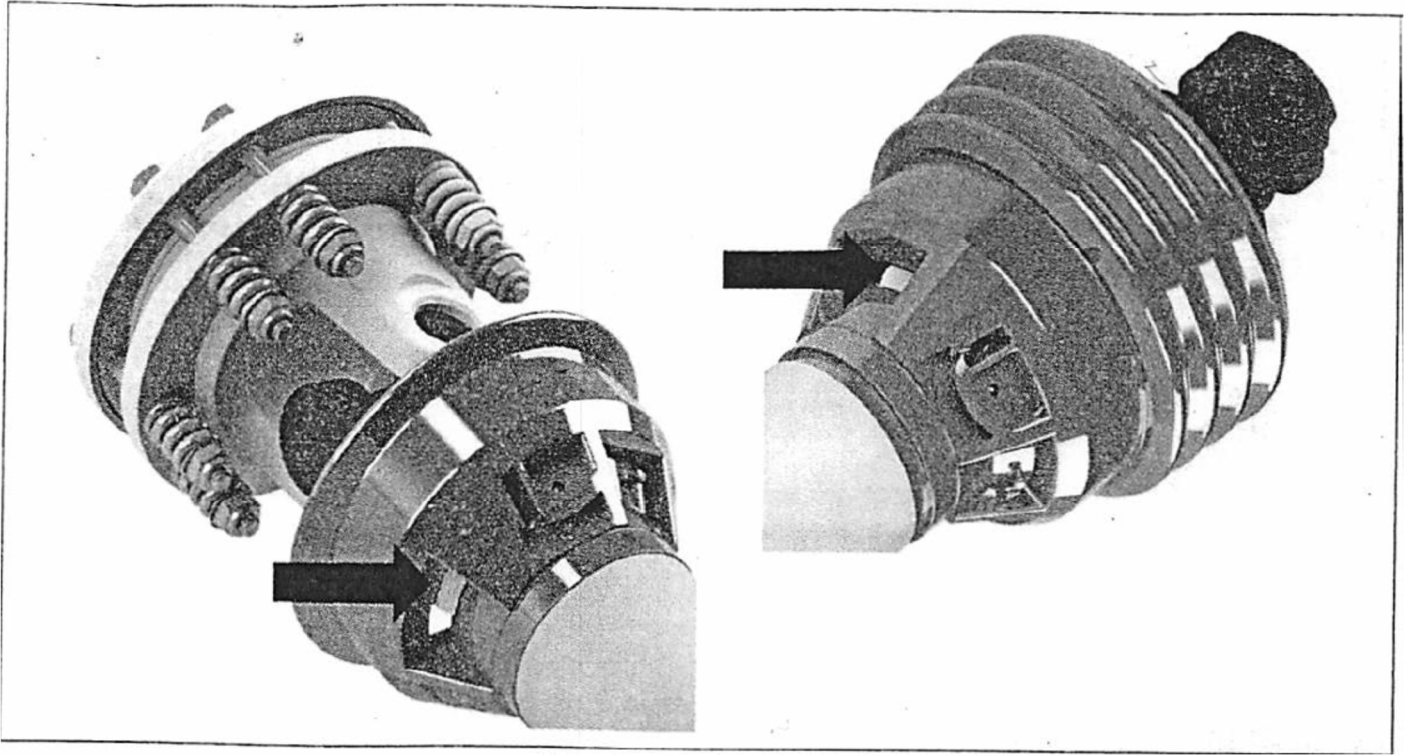

Figure 13 (Step 3)

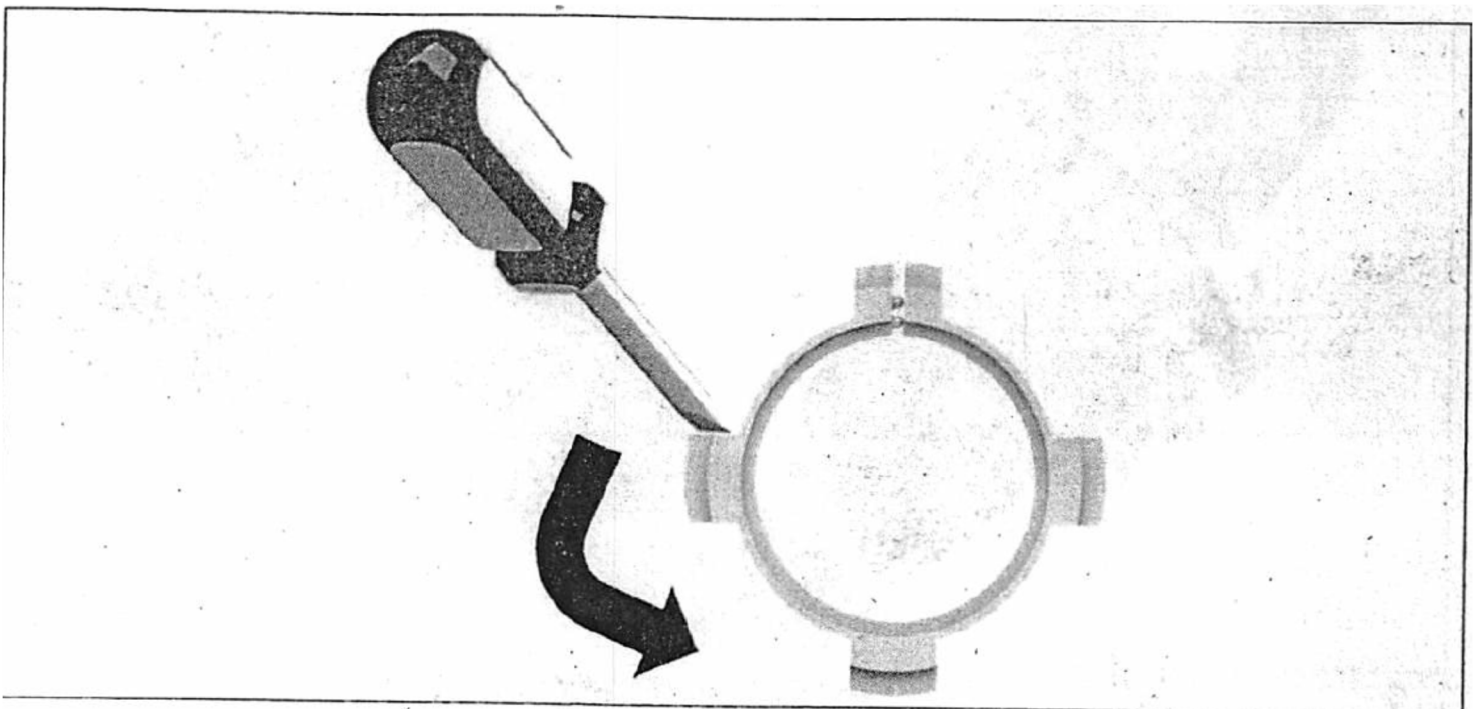

Figure 14 (Step 3)

PTO SHAFTS COVER REMOVAL

RPM Continued

4). With the bearing disengaged, remove the shield from each end of the driveline.

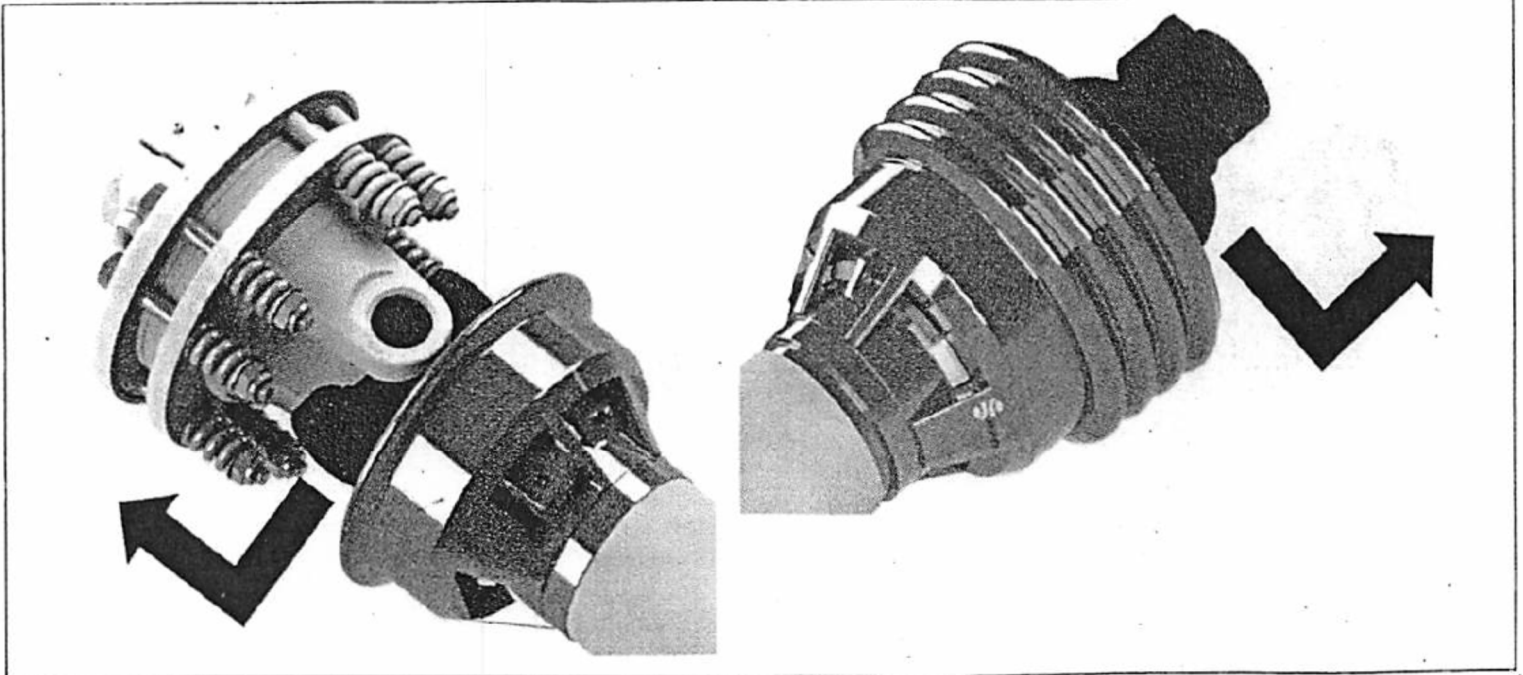

Figure 15 (Step 4)

5). Locate the bearings at either end of the driveline. Rotate each end of the driveline until the split in each bearing is visible.

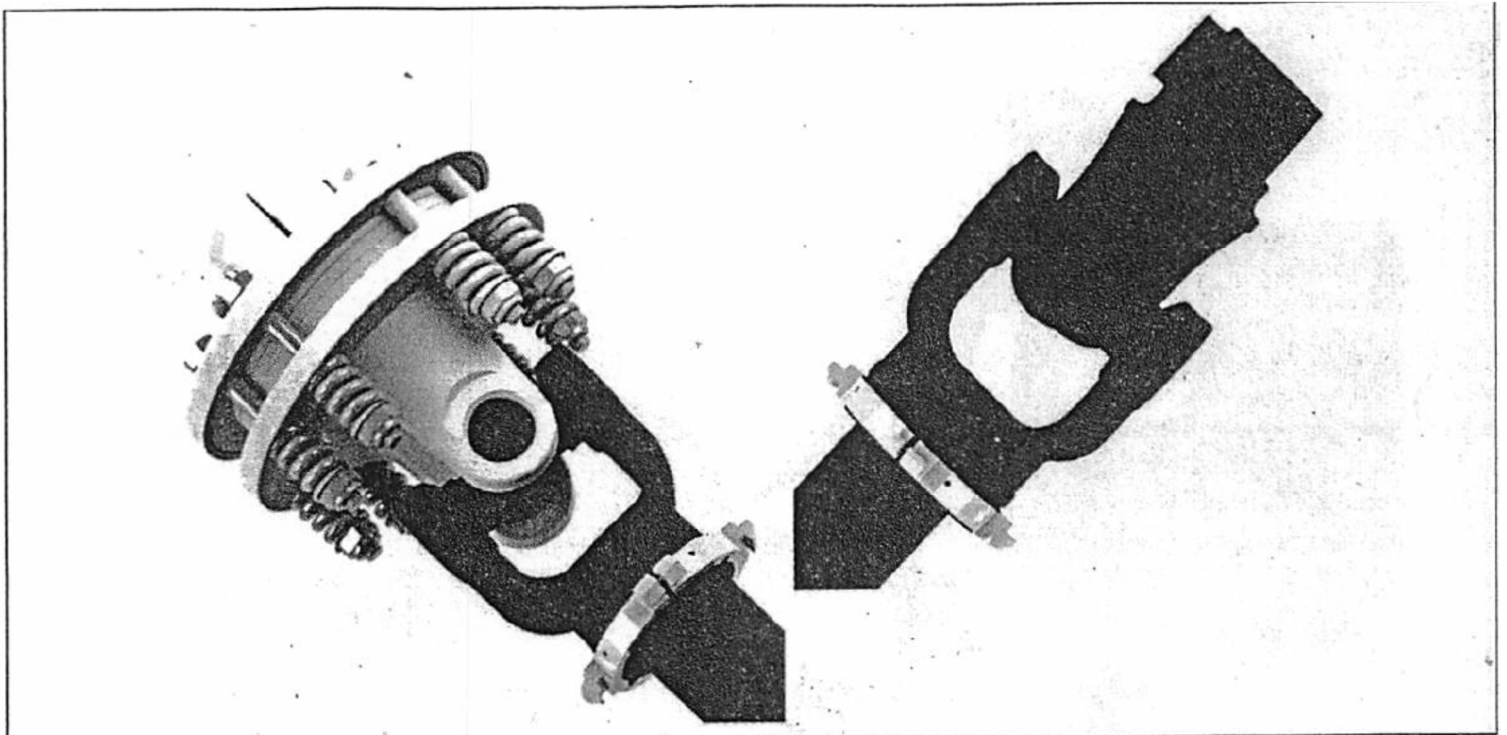

Figure 16 (Step 5)

PTO SHAFTS COVER REMOVAL

RPM Continued

6). Pull outward on the tabs adjacent to the split in the bearing to remove the bearings from either end of the driveline. Please refer to Figure 18, below, for a disassembled driveline.

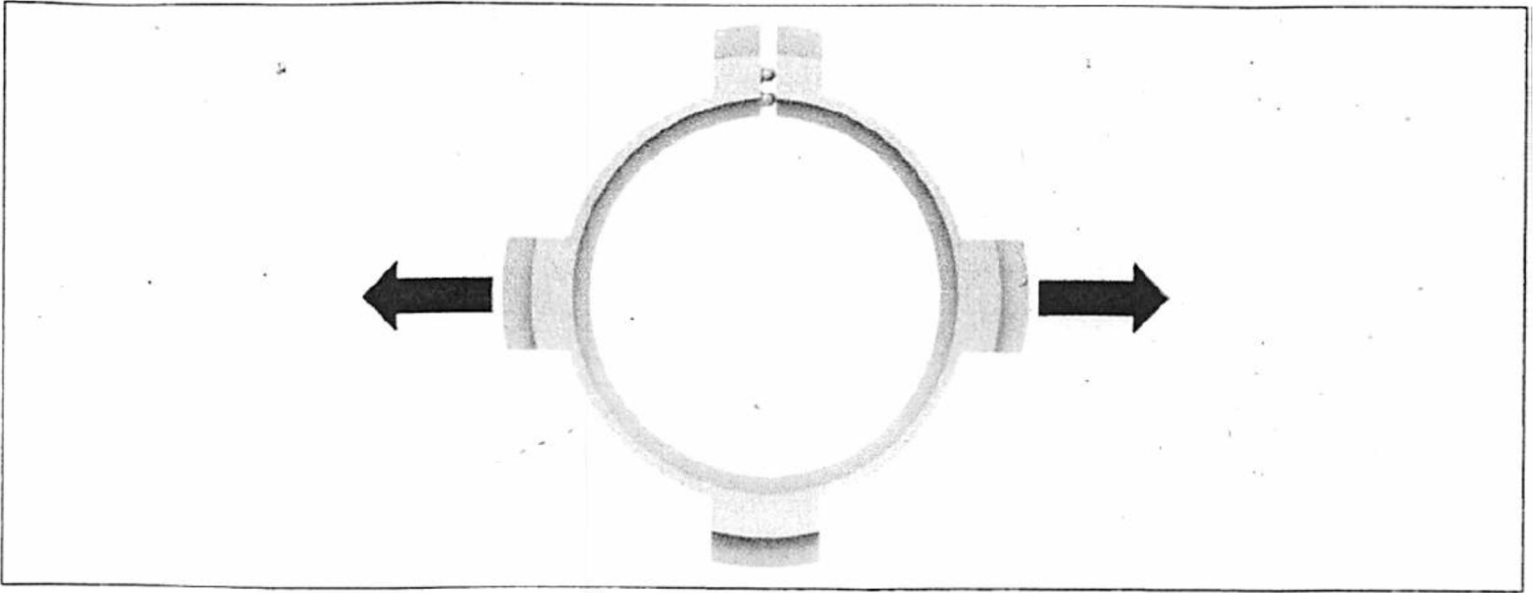

Figure 17 (Step 6)

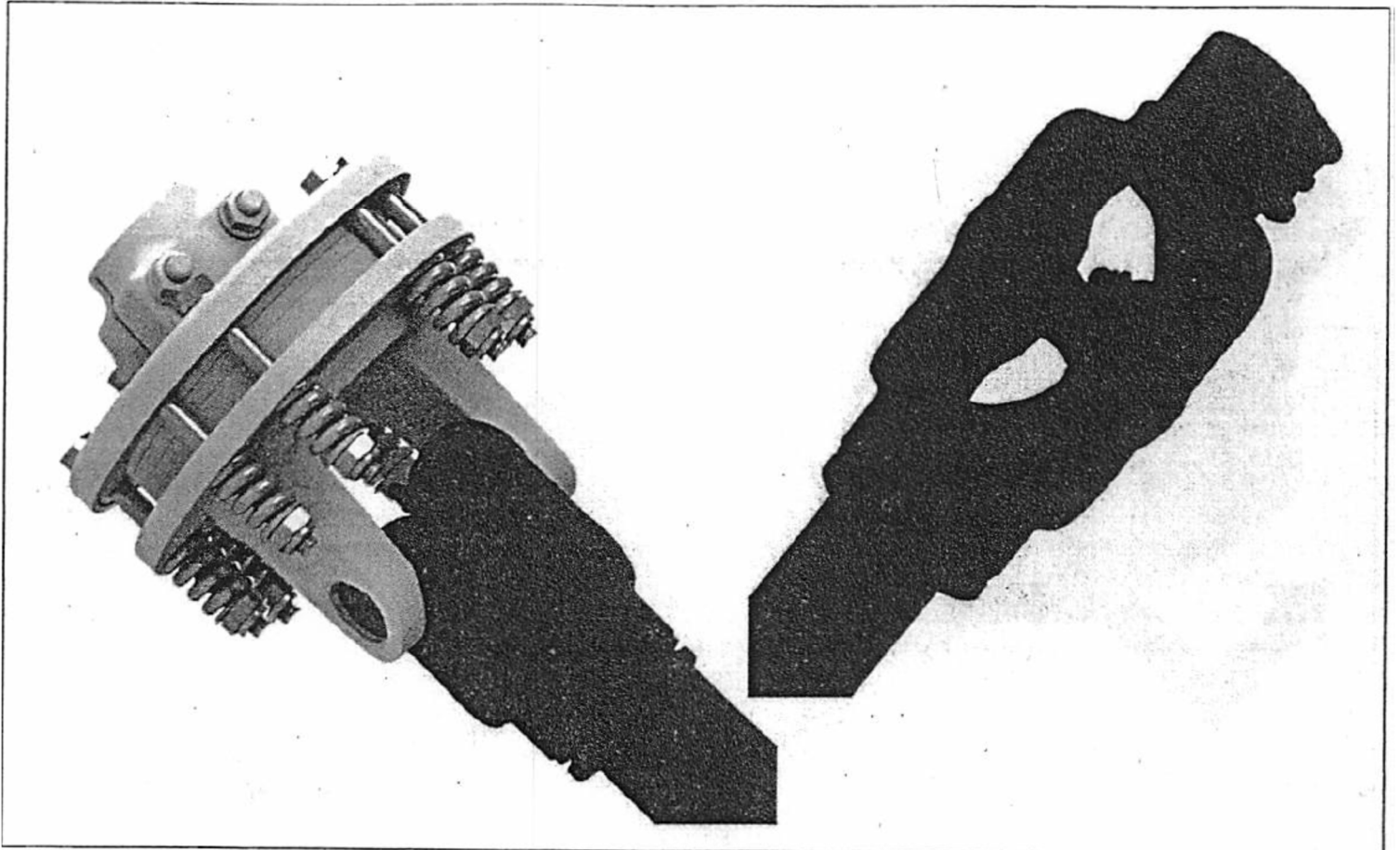

Figure 18 (Step 6)



1. Limited Warranty.

King Kutter, Inc. ("King Kutter"), P.O. Box 1200, Winfield, Alabama 35594, warrants to the original retail purchaser ("Purchaser") that the product that is the subject of this sale is free from defects in material and workmanship at the time of sale.

Under this warranty, King Kutter will repair the defective product free of charge to the Purchaser, with either new or used and reconditioned replacement parts. All warranty service will be performed at service centers designated by King Kutter. If King Kutter is unable to repair the product to conform to the warranty after a reasonable number of attempts, King Kutter will provide, at its option, one of the following: (a) a replacement for the product or, (b) a full refund of the purchase price. Repair, replacement, or refunds are the Purchaser's EXCLUSIVE remedies against King Kutter under this limited warranty. King Kutter will not be liable for any special, incidental or consequential damages based upon breach or warranty, breach of contract, negligence, strict tort liability, or any other legal theory. Such damages include, but are not limited to, loss of profits, loss of savings or revenue, loss of use of the product or any associated equipment, cost of capital, cost of any substitute equipment, facilities or services, down time, the claims of third parties including customers, and injury to property. These limitations also apply, to the extent allowed by law, to personal injury.

The purchaser must notify the Seller in writing of any defect in material or workmanship within one (1) year following the date of purchase. If the equipment is used for commercial purposes, the Purchaser must notify the Seller in writing of any defect in material or workmanship within ninety (90) days following the date of purchase. In no event will King Kutter be liable under this warranty unless written notice is received by the Seller within one (1) year from the date of original retail sale.

2. Warranty of Title.

King Kutter warrants that it transfers a good title to the product free of any encumbrances, and free of the rightful claim of any third party for infringement of patent or copyright.

3. What is Not Covered by This Limited Warranty.

King Kutter will not be responsible for damage to or failure in the product which results from accident, misuse, abuse, neglect, installation of attachments not provided by King Kutter, modifications to the product, or damage caused by use of the product for purposes other than those for which it was designed.

4. No Other Warranties.

Unless modified in writing and signed by both parties, this agreement is understood to be the complete and exclusive agreement and warranty between King Kutter and Purchaser, superseding all prior agreements, oral and written, and all other communication between King Kutter and Purchaser related to the subject matter of this agreement.

THIS LIMITED WARRANTY IS IN LIEU OF ALL OTHER WARRANTIES, EXPRESS OR IMPLIED, INCLUDING, BUT NOT LIMITED TO, THE IMPLIED WARRANTY OF MERCHANTABILITY AND THE IMPLIED WARRANTY OF FITNESS FOR A PARTICULAR PURPOSE. No employee of King Kutter nor anyone else is authorized to make any warranty or representation in addition to or different from those made in this agreement.

5. Allocation of Risk.

This agreement allocates the risk of product failure between King Kutter and the Purchaser. This Allocation is recognized by both parties as reflected in the price of the goods. The Purchaser acknowledges that he or she has read this agreement, understands it, and is bound by its terms.